

# **ECMPS Reporting Instructions Emissions**

United States Environmental Protection Agency  
Office of Air and Radiation  
Clean Air Markets Division  
1310 L Street, NW  
Washington, DC 20005

June 16, 2011



**Table of Contents**

	<b><u>Page</u></b>
<b>1.0 INTRODUCTION: EMISSIONS .....</b>	<b>1</b>
<b>2.0 EMISSIONS.....</b>	<b>5</b>
2.1 SUMMARY VALUE DATA .....	7
2.2 DAILY TEST SUMMARY DATA .....	13
2.2.1 DAILY CALIBRATION DATA .....	17
2.3 DAILY EMISSIONS DATA .....	26
2.3.1 DAILY FUEL DATA .....	28
2.4 HOURLY OPERATING DATA.....	29
2.4.1 MONITOR HOURLY VALUE DATA.....	35
2.4.2 DERIVED HOURLY VALUE DATA.....	57
2.4.3 HOURLY FUEL FLOW DATA.....	73
2.4.3.1 HOURLY PARAMETER FUEL FLOW DATA .....	81
2.5 LONG TERM FUEL FLOW DATA .....	89

## List of Tables

	<u>Page</u>
Table 1 Parameter Codes and Descriptions for SUMMARY VALUE DATA .....	9
Table 2 Precision of Reported Values for SUMMARY VALUE DATA.....	10
Table 3 Test Result Code Descriptions.....	15
Table 4 Precision of Reported Values for DAILY CALIBRATION DATA .....	21
Table 5 Gas Type Codes and Descriptions .....	22
Table 6 Load Units of Measure Codes and Descriptions .....	32
Table 7 Fuel Codes and Descriptions .....	34
Table 8 MHV Elements for SO <sub>2</sub> C or Flow .....	36
Table 9 MHV Elements for NO <sub>x</sub> C Record -- NO <sub>x</sub> Rate System Only .....	37
Table 10 MHV Elements for NO <sub>x</sub> C Record -- NO <sub>x</sub> C System.....	38
Table 11 Summary of NO <sub>x</sub> MONITOR HOURLY VALUE Record Reporting Requirements.....	39
Table 12 MHV Elements for CO <sub>2</sub> C .....	40
Table 13 MHV Elements for O <sub>2</sub> C .....	42
Table 14 MHV Elements for H <sub>2</sub> O.....	44
Table 15 Parameter Codes and Descriptions for the MHV DATA Record .....	45
Table 16 Precision of Reported Values for MONITOR HOURLY VALUE DATA.....	50
Table 17 MODC Codes and Descriptions for MHV .....	50
Table 18 Moisture Basis Codes and Descriptions .....	56
Table 19 Parameter Codes and Descriptions for the DHV DATA Record.....	61
Table 20 Precision of Reported Values for DERIVED HOURLY VALUE DATA.....	66
Table 21 MODC Codes and Descriptions for DHV .....	67
Table 22 System ID Reporting for Derived Hourly Values .....	69
Table 23 Operating Condition Codes and Descriptions .....	70
Table 24 Fuel Codes and Descriptions .....	71
Table 25 Oil Fuel Flow Fuel Codes and Descriptions.....	74
Table 26 Gas Fuel Flow Fuel Codes and Descriptions.....	75
Table 27 Volumetric Units of Measure Codes and Descriptions .....	77
Table 28 Source of Data Volumetric Codes and Descriptions .....	77
Table 29 Source of Data Mass Codes and Descriptions.....	79
Table 30 Parameter Codes and Descriptions for HOURLY PARAMETER FUEL FLOW .....	82
Table 31 Precision of Reported Values for Parameter Value for Fuel .....	83
Table 32 Sample Type Codes and Descriptions .....	84
Table 33 Operating Condition Codes and Descriptions .....	85
Table 34 Units of Measure Codes and Descriptions for HOURLY PARAMETER FUEL FLOW .....	87
Table 35 Long Term Fuel Flow UOM Code .....	92
Table 36 GCV Units of Measure Code.....	93

**List of Figures**

	<b><u>Page</u></b>
Figure 1: EMISSIONS XML SCHEMA COMPLEX Elements .....	3
Figure 2: EMISSIONS XML Elements .....	5
Figure 3: SUMMARY VALUE DATA XML Elements .....	7
Figure 4: DAILY TEST SUMMARY DATA XML Elements .....	13
Figure 5: DAILY CALIBRATION DATA XML Elements .....	17
Figure 6: DAILY EMISSION DATA XML Elements .....	26
Figure 7: DAILY FUEL DATA XML Elements .....	28
Figure 8: HOURLY OPERATING DATA XML Elements .....	29
Figure 9: MONITOR HOURLY VALUE DATA XML Elements .....	35
Figure 10: DERIVED HOURLY VALUE DATA XML Elements .....	57
Figure 11: HOURLY FUEL FLOW DATA XML Elements .....	73
Figure 12: HOURLY PARAMETER FUEL FLOW DATA XML Elements .....	81
Figure 13: LONG TERM FUEL FLOW DATA XML Elements .....	89

*[This page intentionally left blank.]*

## **ECMPS Reporting Instructions Emissions**

### **1.0 INTRODUCTION: EMISSIONS**

#### **About This Document**

In the Emissions Collection and Monitoring Plan System (ECMPS), data must be submitted to the EPA through the Client Tool using extensible-markup language (XML) format. XML files must contain certain data elements, which are defined in the XML schema. (Note: More information about the ECMPS XML Schemas can be found in the XML Schema Description Documents.)

The purpose of the reporting instructions is to provide the necessary information for owners and operators to meet the reporting requirements for sources affected by:

- 1) The Acid Rain Program (ARP);
- 2) The Clean Air Interstate Rule (CAIR); and
- 3) Other programs required to report data using these XML schemas.

These instructions explain how to report the required data for the applicable regulations. Owners and operators of units should refer to the applicable regulations for information about what data are required to be reported.

The Emissions XML Schema is made up of a root element, complex elements, and simple elements. A simple element is a single piece of data. A complex element is a group of simple elements which are logically grouped together. The root element is the base of the XML schema.

The elements are related to each other in parent-child relationships. The root element is the parent element of the entire schema. Complex elements are children of the root element, and complex elements can also be children of other complex elements. If a complex element is dependent on a parent complex element, the child complex element cannot be included in the XML file unless the appropriate parent complex element is also included. Figure 1 below illustrates the relationships between the emissions root element and the complex elements.

This document provides instructions on how the required data should be reported using this data structure. A separate section is provided for each complex element, its dependencies, and its simple elements. In addition, there are "specific considerations" that apply to particular types of monitoring plan configurations.

#### **About Emissions Data**

Emissions data are hourly values for measured parameters, calculated hourly emissions values, instrument calibration data, and aggregated summary data. An emissions file contains one

calendar quarter of hourly and aggregate emissions measurements for a specified unit or group of related units, including stacks and pipes.

Each unit that is required to submit emissions data for a particular calendar quarter must be included in one and only one emissions file for that quarter. Each emissions file should contain all relevant operating, daily quality assurance, and emissions data for all units, common stacks, multiple stacks, or common pipes that were in a common monitoring configuration for any part of the quarter.

You must submit an emissions file for each quarter or, for ozone season only reporters, for the second and third calendar quarters of each year.

### **Rounding Conventions for Reporting Emissions Values**

Each emissions value that is reported must be rounded to a specified number of decimal places. The appropriate number of decimal places is based on the parameter, fuel type, and/or record type. Because some fields were designed to be generic and support reporting data for different parameters, it is not always appropriate to report values to the number of decimal places in the XML format. The appropriate precision for each parameter (and fuel type) can be found in the instructions under each record type.

Use the standard arithmetic rounding convention where numbers five through nine round to the next highest number in the previous decimal position to the left.

For example, when reporting SO<sub>2</sub>C, NO<sub>x</sub>C, CO<sub>2</sub>C, O<sub>2</sub>C, or H<sub>2</sub>O in the MONITOR HOURLY VALUE DATA (MHV) record, round these values to the nearest 0.1 ppm or 0.1 percent (as applicable). When reporting FLOW, the last significant digit in the reported flow rate values is in the thousands place; fill in zeros in the hundreds, tens, and unit columns (e.g., round 15,922,855 scfh to 15,923,000 scfh). When reporting NO<sub>x</sub>R in the DERIVED HOURLY VALUE DATA (DHV) record, round the NO<sub>x</sub> emission rate to three decimal places.

### **Use of Rounded and Unrounded Values in Emissions Calculations**

When performing calculations using any value that is reported in the XML, use the value as it is reported. In other words, use the rounded value in the calculation. However, any value that is calculated in an intermediate equation but is not reported should not be rounded before using it in a subsequent equation.

For example, to calculate the bias-adjusted SO<sub>2</sub> concentration, multiply the UnadjustedHourlyValue in the SO<sub>2</sub>C MHV record (which has been reported as a value rounded to one decimal place) by the bias adjustment factor (which has been reported in the RATA as a value rounded to three decimal places), and round the result to one decimal place before reporting this value as the AdjustedHourlyValue in the MHV record. To calculate the hourly SO<sub>2</sub> mass rate in lb/hr using formula F-1, use the AdjustedHourlyValue in the SO<sub>2</sub>C MHV record (which has been rounded to one decimal place) and AdjustedHourlyValue in the FLOW MHV record (which has been rounded to the nearest thousand) in the equation, and round the result to one decimal place before reporting this value as the AdjustedHourlyValue in the SO<sub>2</sub> DHV record. When calculating quarterly SO<sub>2</sub> emissions in tons, first multiply the

AdjustedHourlyValue in the SO2 DHV record (which has been rounded to one decimal place) by the OperatingTime (which has been rounded to two decimal places) for every hour. Sum these unrounded products, then divide this unrounded sum by 2,000. Finally, round the result to one decimal place before reporting the quarterly emissions value in SUMMARY VALUE DATA record.

**Figure 1**  
**EMISSIONS XML SCHEMA COMPLEX Elements**

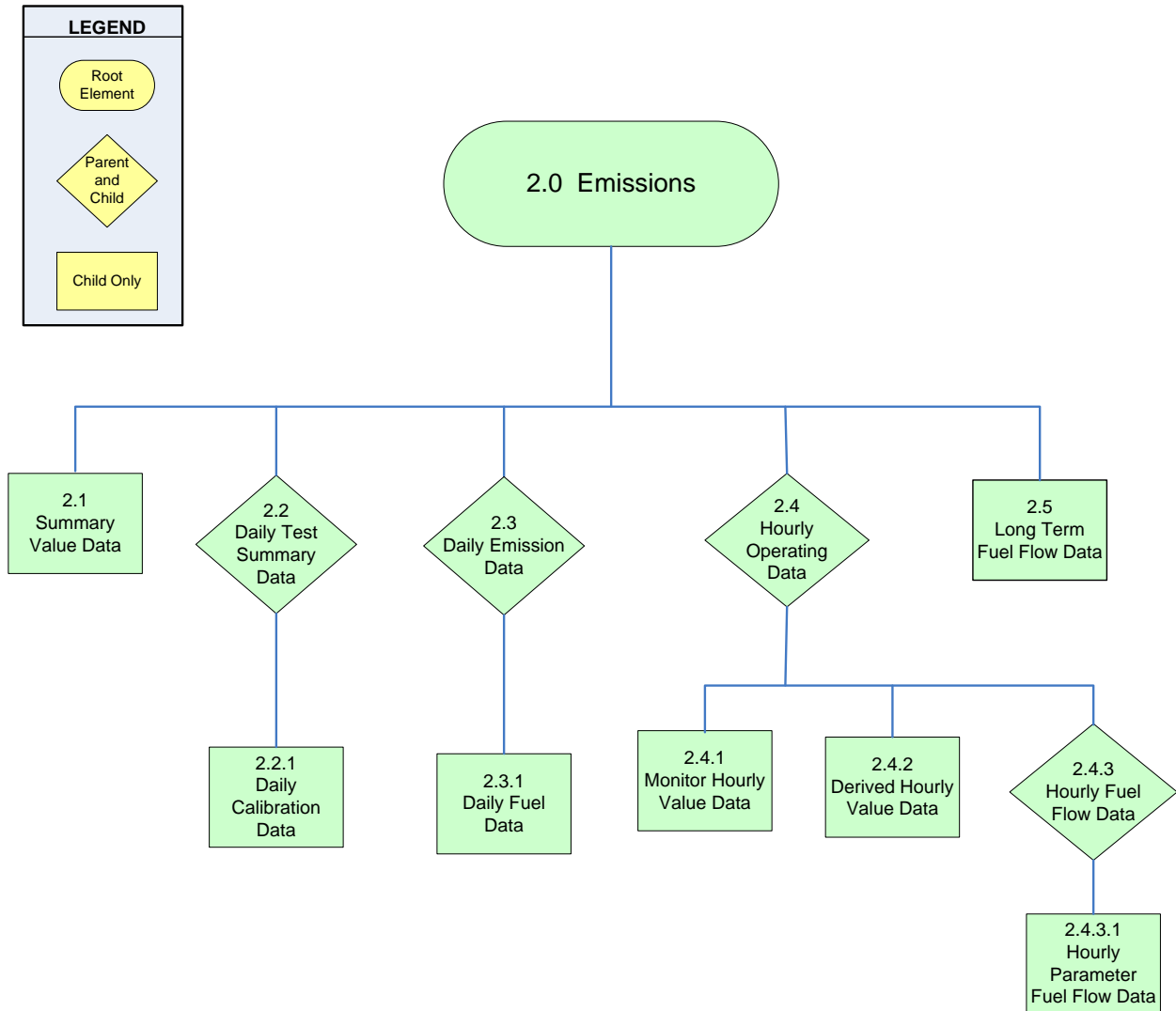

*[This page intentionally left blank.]*

## 2.0 EMISSIONS

### EMISSIONS XML Model

**Figure 2**  
**EMISSIONS XML Elements**

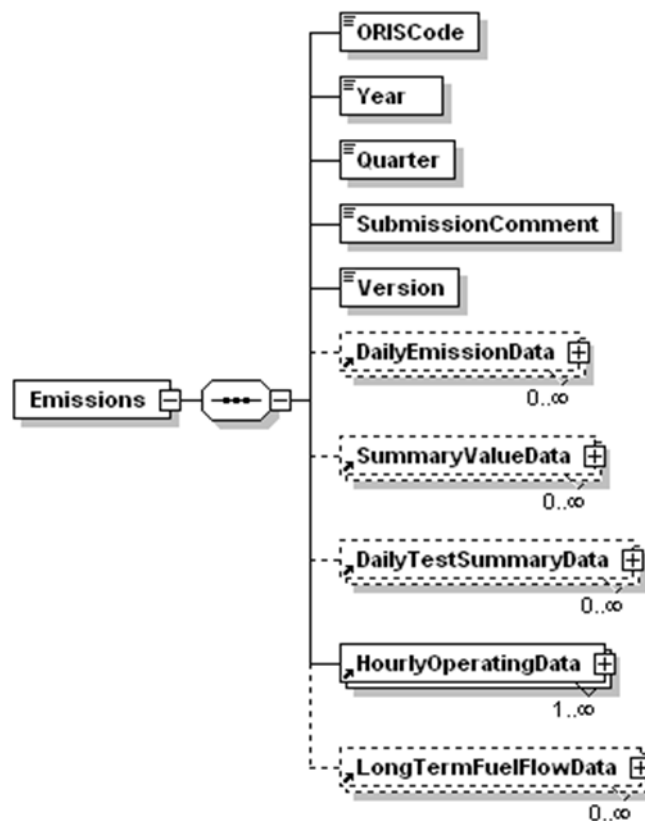

### EMISSIONS Overview

#### Description of Data

The EMISSIONS record is the root element for the Emissions data XML schema. This element identifies the source for which emissions data are being reported. In addition, it provides information about the reporting period for which data are provided by identifying the year and quarter. Include a single EMISSIONS record in each Emissions data file.

**EMISSIONS XML Elements****ORIS Code***Element Name: ORISCode*

Report the code that indicates the unique identification number given to a source by the Energy Information Administration (EIA).

**Year***Element Name: Year*

Report the calendar year represented by the data in the file.

**Quarter***Element Name: Quarter*

Report the calendar quarter represented by the data in the file. Be sure that the reported year and quarter are properly matched to the time period of the emissions data.

**Submission Comment***Element Name: SubmissionComment*

This field can be used to report additional information or provide an explanation about an event that is specific to the quarterly report. Report the text of the comment in this field.

**Version***Element Name: Version*

Report the XML schema version number. Note that this is a numeric field -- do not include a "v" before the number.

## 2.1 SUMMARY VALUE DATA

### SUMMARY VALUE DATA XML Model

**Figure 3**  
SUMMARY VALUE DATA XML Elements

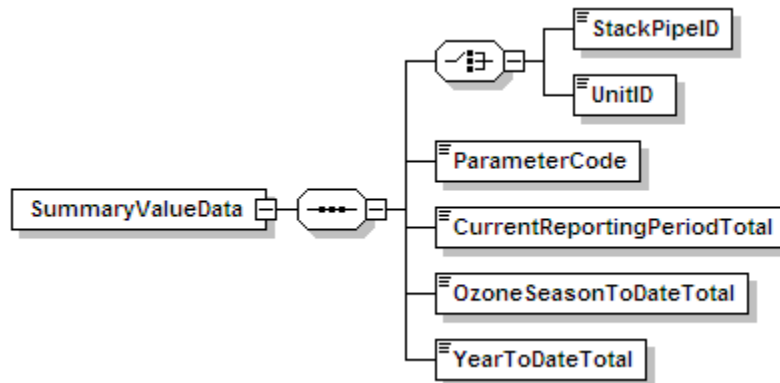

### SUMMARY VALUE DATA Overview

#### Description of Data

The SUMMARY VALUE DATA records are used to report aggregated values for the parameters included in the emissions submission file and cumulative values for the year and/or ozone season. Summary values are reported by monitoring location and parameter on the basis of the current reporting period, year-to-date, and, if relevant, ozone season-to-date sums (or averages). For each monitoring location in the file, report a SUMMARY VALUE DATA record for operating time and another for operating hours. Also report a SUMMARY VALUE DATA record for each parameter measured or calculated at that location to meet a regulatory requirement. See Table 1 below for applicable parameters.

For units required to report heat input (HI), you must include for each unit a SUMMARY VALUE DATA record for HI whether the HI was actually measured at the unit level or apportioned (or summed) from another location or multiple locations.

#### Common Stacks or Pipes

The reporting period and cumulative heat input values for the stack or pipe (in mmBtu) must equal the sum of the HIs for the units associated with the stack or pipe. For the individual units, report SUMMARY VALUE DATA records only for HI, operating time, and operating hours. Do not apportion SO<sub>2</sub> mass emissions, CO<sub>2</sub> mass emissions, or average NO<sub>x</sub> emission rates to the individual units.

### Multiple Stacks or Pipes

For these configurations, report only the reporting period and cumulative HI, operating time, operating hours, and weighted average NO<sub>x</sub> emission rates in the unit-level SUMMARY VALUE DATA records. Do not report quarterly and cumulative SO<sub>2</sub> or CO<sub>2</sub> mass emissions at the unit level. The reported quarterly or cumulative HI value for the unit must equal the sum of the corresponding HI values reported for the individual stacks, ducts, or pipes.

### Complex Stack Configurations

A complex stack configuration exists where a unit's emissions are measured at more than one stack location and where at least one of these stack locations is a common stack shared with one or more other units.

For the purposes of quarterly and cumulative HI accounting, the sum of the HIs for all units associated with all stacks in a complex configuration must equal the sum of the stack HIs for all of the stacks. For example, if emissions from scrubbed Units 1, 2, and 3 are measured at CS1 during normal unit operation and are measured at CS2 during scrubber bypass hours, the sum of the HIs for Units 1, 2, and 3 must equal the sum of the HIs for CS1 and CS2.

See "Specific Considerations" below for information about how to calculate summary values.

## **SUMMARY VALUE DATA XML Elements**

### **Unit ID or Stack Pipe ID**

*Element Name: UnitID or StackPipeID*

Report either the Unit ID or Stack Pipe ID that corresponds to the summary data value location. This is the alphanumeric code assigned by a source to identify a unit, stack, or pipe.

### **Parameter Code**

*Element Name: ParameterCode*

Report the Parameter Code for the parameter summarized by this SUMMARY VALUE DATA record. Use the appropriate uppercase code as shown in Table 1.

**Table 1**  
**Parameter Codes and Descriptions for SUMMARY VALUE DATA**

Code	Description
BCO2	Biogenic CO <sub>2</sub> Mass (tons) This is only for RGGI affected units
CO2M	Carbon Dioxide Mass (tons)
HIT	Heat Input Total (mmBtu)
NOXM	Nitrogen Oxide Mass (tons)
NOXR	Nitrogen Oxide Rate (lb/mmBtu)
OPTIME	Operating Time (hr)
OPHOURS	Number of Operating Hours
SO2M	Sulfur Dioxide Mass (tons)

### **Current Reporting Period Total**

*Element Name: CurrentReportingPeriodTotal*

Report the cumulative parameter value (i.e., emissions or time) as measured from the beginning of the current reporting period to the end of the current reporting period. This will generally be the quarterly total (or average), except for the second calendar quarter file for ozone season only reporters. For those files, this value is the total (or average) for just May and June. The value should be rounded to the number of decimal places according to Table 2. If there was no operation at this location during the reporting period, report zero.

### **Ozone Season to Date Total**

*Element Name: OzoneSeasonToDateTotal*

For locations subject to ozone season only programs, report the cumulative parameter value (i.e., emissions or time) for the ozone season as follows: For a first quarter report, leave this field blank. For a second quarter report, report the sum parameter value (i.e., emissions or time) from the beginning of the ozone season (May 1) to the end of the reporting period. For a third quarter report, report the sum of the Ozone Season to Date Total value reported in the second quarter plus the quarterly value for the parameter reported for the third quarter. For a fourth quarter report, report the Ozone Season to date total from the third quarter report. All values should be rounded to the number of decimal places according to Table 2. If there was no operation at this location during the ozone season, report zero. For locations not subject to ozone season only programs, leave this field blank.

### **Year to Date Total**

*Element Name: YearToDateTotal*

For locations that report year-round, report the cumulative sum of current year quarterly totals for each parameter value (i.e., emissions or time) as follows: For a first quarter report, report the sum parameter value (i.e., emissions or time) for the quarter. For subsequent quarters, report the

sum of the current reporting period plus the quarterly values for the parameter reported in the previous quarters. For example, the Year to Date total for quarter three would be calculated by summing the current quarter three reporting period value with the previously reported quarter one and quarter two values. The value should be rounded to the number of decimal places according to Table 2. If there was no operation at this location during the calendar year-to-date, report zero. For ozone season only reporters, leave this field blank.

**Table 2**  
**Precision of Reported Values for SUMMARY VALUE DATA**

Parameter Codes	Number of Decimal Places
CO2M, NOXM, SO2M, BCO2	One
OPTIME	Two
NOXR	Three
HIT	Zero

### *Specific Considerations*

#### **Operating Time and Operating Hours**

- Operating Time is the sum of the hourly OperatingTime in HOURLY OPERATING DATA records. Operating Hours is a count of HOURLY OPERATING DATA records with OperatingTime greater than zero.

#### **SO2M, NOXM, HIT, and CO2M from Hourly Data**

- For non-Low Mass Emissions (LME) locations, to calculate Reporting Period, Year to Date, and Ozone Season to Date totals for SO2M, and NOXM, multiply each hourly rate value reported in the DERIVED HOURLY VALUE record by the corresponding operating time in the HOURLY OPERATING record, sum those values, and then divide by 2,000. Round the resulting sum to the appropriate number of decimal places per Table 2. For CO2M, follow the same procedure but do not divide by 2,000.
- For LME units, to calculate Reporting Period, Year to Date, and Ozone Season to Date totals for SO2M, NOXM and HIT, sum the values in the DERIVED HOURLY VALUE records and divide by 2,000. Round the resulting sum to the appropriate number of decimal places per Table 2. For CO2M, follow the same procedure but do not divide by 2,000.
- If a common fuel pipe (or supply tank) serves a group of LME units and the long-term fuel flow option is used to quantify heat input, report the cumulative heat input for the group of units under the common pipe (or tank) ID. If more than one common pipe (or tank) serves the same group of LME units, report a separate SUMMARY VALUE DATA record for Total Heat Input (HIT) for each pipe (or tank).

### CO<sub>2</sub>M from Daily Data

- If CO<sub>2</sub> mass is calculated on a daily basis and reported in the DAILY EMISSIONS DATA record, calculate Reporting Period, Year to Date, and Ozone Season to Date for CO<sub>2</sub>M by summing the values in these records. Round the resulting sum to the appropriate number of decimal places per Table 2.

### NO<sub>x</sub> Emission Rate

- For non-Acid Rain units, do not report a SUMMARY VALUE DATA record for NO<sub>x</sub>R, even if the NO<sub>x</sub> emission rate is calculated on an hourly basis for the purpose of determining NO<sub>x</sub> mass rate (lb/hr).
- Calculate summary NO<sub>x</sub> emission rates as a straight arithmetic average of the NO<sub>x</sub> emission rates for all operating hours in the reporting period, ozone season, or year-to-date period, as reported in the DERIVED HOURLY VALUE DATA. If the recorded NO<sub>x</sub> emission rate is zero, include these hours in the average only if the operating time for the hour is greater than zero.
- Do not weight the quarterly or cumulative average NO<sub>x</sub> emission rate for partial operating hours (i.e., count all hourly NO<sub>x</sub> emission rates equally, irrespective of the unit operating time). Report both the quarterly and cumulative average NO<sub>x</sub> emission rates for the unit or stack to three decimal places.
- For simple multiple stack or multiple duct configurations in which NO<sub>x</sub> emissions and heat input are monitored separately in each of the stacks or ducts, you must calculate and report the quarterly and cumulative arithmetic average NO<sub>x</sub> emission rate for each stack or duct, and you must also calculate and report a quarterly and cumulative heat input-weighted NO<sub>x</sub> emission rate for the unit. Determine the heat input-weighted averages for the unit as follows. First, use the reported hourly data (i.e., stack level NO<sub>x</sub> emission and heat input rates) and the following formula to calculate a heat input-weighted unit NO<sub>x</sub> emission rate for each stack operating hour in the quarter:

$$\text{Hourly Unit NO}_x \text{ Emission Rate (lb/mmBtu)} = \frac{(\text{NO}_x \text{ Rate})_A(\text{Heat Input})_A + (\text{NO}_x \text{ Rate})_B(\text{Heat Input})_B}{(\text{Heat Input})_A + (\text{Heat Input})_B}$$

- In the formula above, the term "Heat Input" for multiple stack A or B is the product of the hourly HI rate for the stack and the corresponding operating time for the stack.
- When a multiple-stack configuration is selected for a combined-cycle combustion turbine (CT) that: (a) uses the provisions of Appendix D to Part 75 for unit HI; and (b) has a main stack and bypass stack configuration; and (c) has NO<sub>x</sub>-diluent monitoring systems on both the main and bypass stacks, the mathematics are slightly different. In this case, for any unit operating hour in which gases flow through both stacks for any part of the hour, a time-weighted, rather than a heat-input-weighted unit-level NO<sub>x</sub> emission rate is calculated, using an equation similar to the one above, except that the terms "(Heat Input)A" and "(Heat Input)B" are replaced with tA and tB, respectively, where tA and tB

are the main stack operating time and bypass stack operating time, respectively. The time-weighted hourly average NO<sub>x</sub> emission rates are then used to determine the quarterly and cumulative NO<sub>x</sub> emission rates for the unit.

- The quarterly heat input-weighted average NO<sub>x</sub> emission rate for the unit is then determined by taking the sum of all of the hourly heat input-weighted NO<sub>x</sub> emission rates for the quarter and dividing this sum by the total number of unit operating hours in the quarter. In determining the number of unit operating hours in the quarter, each partial operating hour is counted as a full hour of unit operation. The cumulative heat input-weighted average NO<sub>x</sub> emission rate for the unit is determined in the same way as the quarterly average for the unit, except that the terms "for the quarter" and "in the quarter" are replaced, respectively, with the terms, "for the year, to date" and "in the year, to date."
- For Acid Rain Program (ARP) LME units, determine the quarterly average NO<sub>x</sub> emission rate for each unit as follows: Sum all of the hourly NO<sub>x</sub> mass values from the DERIVED HOURLY VALUE records for NO<sub>x</sub> to get the total NO<sub>x</sub> mass for the quarter. Then, sum the hourly HI values from the DERIVED HOURLY VALUE records for HI to obtain the HIT for the quarter. Divide the total NO<sub>x</sub> mass for the quarter by the total quarterly HI, to determine the quarterly NO<sub>x</sub> emission rate in lb/mmBtu. Calculate the cumulative (year-to-date) NO<sub>x</sub> emission rate by separately summing the hourly NO<sub>x</sub> mass and HI values over all operating hours in all quarters, and then dividing the NO<sub>x</sub> mass sum by the HI sum.

## 2.2 DAILY TEST SUMMARY DATA

### DAILY TEST SUMMARY DATA XML Model

Figure 4  
DAILY TEST SUMMARY DATA XML Elements

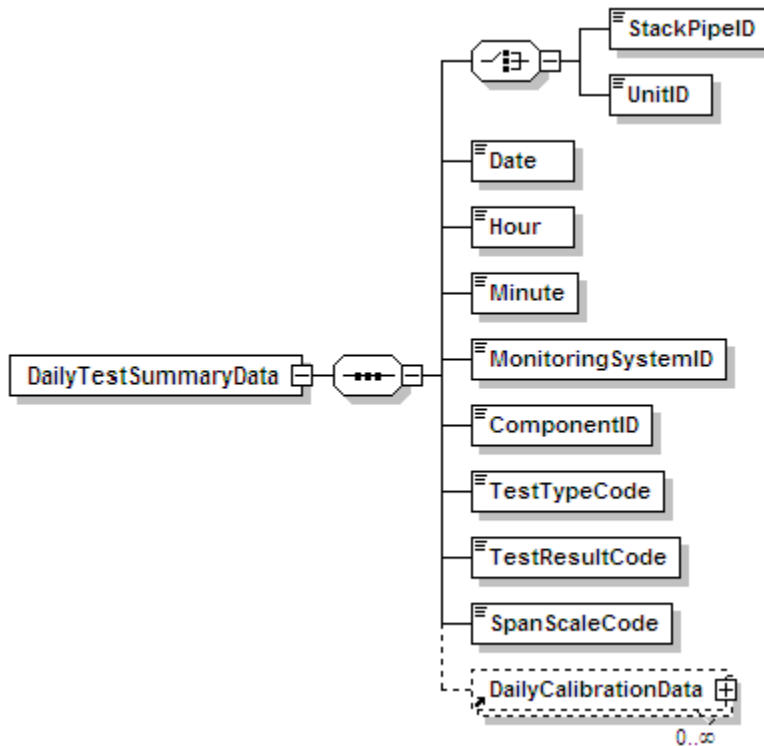

### DAILY TEST SUMMARY DATA Overview

#### Description of Data

The DAILY TEST SUMMARY DATA record summarizes the completion date and time and the results (Passed/Failed/Aborted) for each daily calibration error test and flow interference check. For each calibration error test, report the calibration test data in the DAILY CALIBRATION DATA record. (See instructions for that record below.) Also use the DAILY TEST SUMMARY DATA record to report the results of the daily Predictive Emissions Monitoring System (PEMS) calibration for units with an approved PEMS monitoring method.

Report the results of all failed, passing, and incomplete calibrations that affect data validation. For redundant backup monitors, the results of daily calibration error tests need not be reported except on days when using the monitors to report emissions data.

Do not report the results of off-line calibrations performed during periods of non-operation of the unit or stack unless the unit has passed the off-line calibration demonstration and is using off-line calibrations to validate data.

**DAILY TEST SUMMARY DATA XML Elements****Unit ID or Stack Pipe ID**

*Element Name: UnitID or StackPipeID*

Report either the Unit ID or Stack Pipe ID for the daily test location. This is the alphanumeric code assigned by a source to identify a unit or stack.

**Date**

*Element Name: Date*

For daily calibrations, report the date corresponding to the completion of the last gas injection of the test. For interference checks, report the date on which the test was completed.

**Hour**

*Element Name: Hour*

For daily calibrations, report the hour corresponding to the completion of the last gas injection of the test. For interference checks, report the hour in which the test was completed.

**Minute**

*Element Name: Minute*

For daily calibrations, report the minute corresponding to the completion of the last gas injection of the test. For interference checks, report the minute in which the test was completed.

**Monitoring System ID**

*Element Name: MonitoringSystemID*

If this is a PEMS Calibration test, report the three-character Monitoring System ID for the NOXP system. Leave this field blank for other parameters.

**Component ID**

*Element Name: ComponentID*

Report the three-character ID assigned to the component. Leave this field blank for PEMSCAL.

**Test Type Code**

*Element Name: TestTypeCode*

Report the test type code as DAYCAL for a daily calibration test summary record, or as INTCHK for an interference check. For units with an approved PEMS methodology, report the test type code as PEMSCAL for daily PEMS calibration tests.

**Test Result Code**

*Element Name: TestResultCode*

Report the test result code as PASSED, PASSAPS, FAILED, INC, or ABORTED. See detailed descriptions of each code in Table 3.

**Table 3**  
**Test Result Code Descriptions**

Code	Description
PASSED	Report whenever the standard performance specification is met for the test. For daily calibration error tests, report the test as passed only if the zero and upscale-level calibration error test injections each pass the standard performance specification in sequence. Partial calibrations, where only one injection level is completed and passes the performance specification, may not be reported as "PASSED." Rather, these may either be omitted from the electronic report or reported as "INC."
PASSAPS	This code applies to daily calibration tests only. Report whenever the standard performance specification was not met for one or both injections, but the alternative performance specification (as described in Appendix B, Section 2.1.4(a)) was met for whichever injections did not meet the standard specification.
FAILED	Report whenever the applicable performance specification is not met for the test. For daily calibration error tests, report the test as failed whenever either the zero-level calibration error test or upscale-level calibration error test (or both) have failed to meet the applicable performance specification. Partial calibrations, where only one injection level is completed and failed, must be reported as "FAILED." Data for the systems associated with the specified component will be considered invalid until a subsequent retest is passed.
INC	Report whenever a calibration error test is not completed at both required calibration levels and the completed calibration injection passes the applicable performance specification tests. Incomplete tests have no affect on data validation and do not satisfy the daily calibration requirements of Part 75.
ABORTED	Report whenever a test is aborted due to a malfunction of the monitoring system. Data for the systems associated with the specified component will be considered invalid until a subsequent retest is passed.

### Span Scale Code

*Element Name: SpanScaleCode*

For Daily Calibration tests, report whether the component or the range of the instrument tested is high (H) or low (L) scale (If the component is a single range and no default high range is in use, enter "H"). Do not report a span scale code for flow monitor components.

*[This page intentionally left blank.]*

## 2.2.1 DAILY CALIBRATION DATA

### DAILY CALIBRATION DATA XML Model

**Figure 5**  
**DAILY CALIBRATION DATA XML Elements**

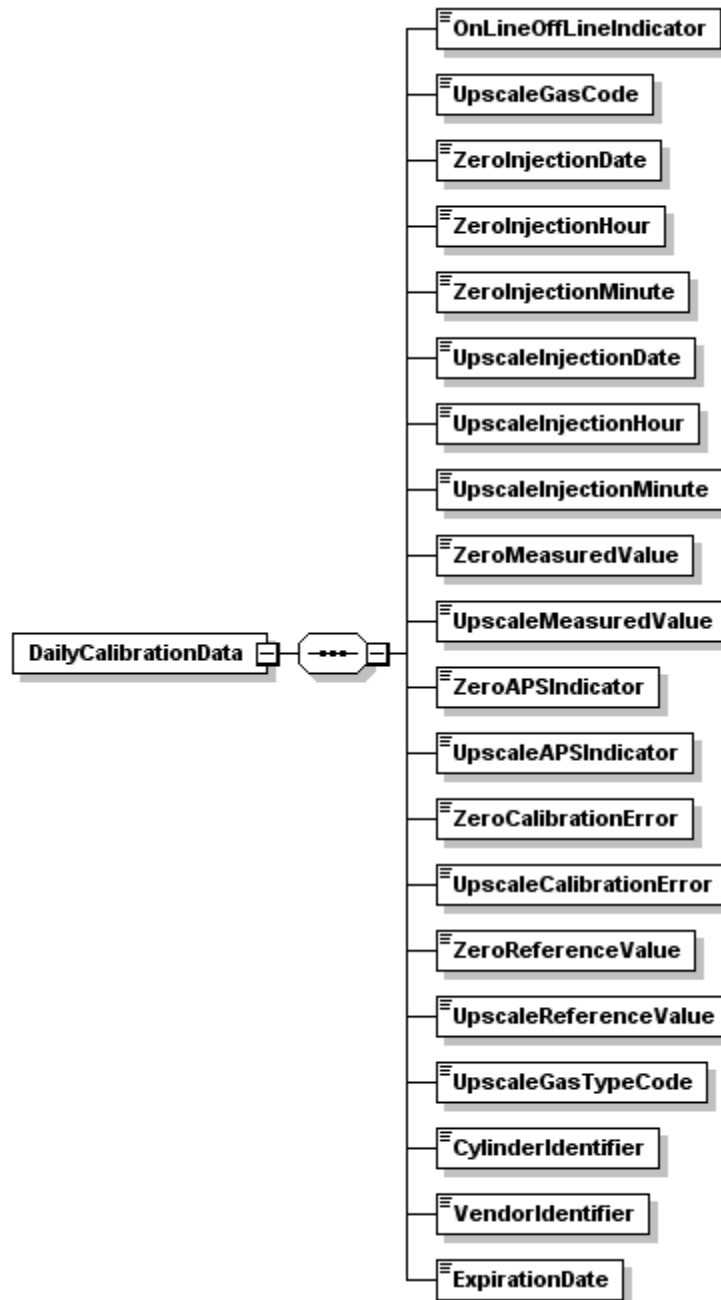

## DAILY CALIBRATION DATA Overview

### Description of Data

The DAILY CALIBRATION DATA record is used to report the details of each daily calibration error test sequence completed. You must report a DAILY CALIBRATION DATA record for each calibration error test performed that affects data validation. A complete DAILY CALIBRATION DATA record should contain data for both the zero and upscale calibration point.

Partial calibration error tests (where the tested level passes the applicable specification) do not satisfy the daily calibration error requirements and are not required to be reported since they have no affect on data validation. If such calibrations are included in the emissions report, then report the result as "INC" in the DAILY TEST SUMMARY DATA record. Partial calibration error tests where the tested level fails to meet the applicable specification must be reported as a "FAILED" test. You are not required to report additional failed calibration tests for a component when the data from that component is already considered invalid due to a previously failed calibration error test. However, please note that tests reported as "FAILED" should be reported with all the necessary fields completed.

For more information concerning this record regarding moisture monitoring systems, flow monitors, maintenance procedures, or dual range analyzers, see the "Specific Considerations" section below.

### DAILY CALIBRATION DATA XML Elements

Instructions for completing each element of the HOURLY SUBMISSION COMMENT DATA section are provided below:

#### OnLine OffLine Indicator

*Element Name: OnLineOffLineIndicator*

Indicate whether this daily calibration was performed online (report "1") or offline (report "0").

#### Upscale Gas Code

*Element Name: UpscaleGasCode*

Indicate whether the gas used for the upscale injection is high-level or mid-level by reporting the appropriate code (HIGH or MID). Mid-level gas injections may be performed and reported in lieu of the high-level injections, provided that the mid-level (MID) gas is more representative of the actual stack emissions. If the daily calibration was not completed and there was no upscale-level injection, leave this field blank.

#### Zero Injection Date

*Element Name: ZeroInjectionDate*

Report the date of the completion of the zero gas injection. If the daily calibration was not completed and there was no zero-level injection, leave this field blank.

**Zero Injection Hour**

*Element Name: ZeroInjectionHour*

Report the hour of the completion of the zero gas injection. If the daily calibration was not completed and there was no zero-level injection, leave this field blank.

**Zero Injection Minute**

*Element Name: ZeroInjectionMinute*

Report the minute of the completion of the zero gas injection. If the daily calibration was not completed and there was no zero-level injection, leave this field blank.

**Upscale Injection Date**

*Element Name: UpscaleInjectionDate*

Report the date of the completion of the upscale gas injection. If the daily calibration was not completed and there was no upscale-level injection, leave this field blank.

**Upscale Injection Hour**

*Element Name: UpscaleInjectionHour*

Report the hour of the completion of the gas injection. If the daily calibration was not completed and there was no upscale-level injection, leave this field blank.

**Upscale Injection Minute**

*Element Name: UpscaleInjectionMinute*

Report the minute of the completion of the upscale gas injection. If the daily calibration was not completed and there was no upscale-level injection, leave this field blank.

**Zero Measured Value**

*Element Name: ZeroMeasuredValue*

Report the value measured by the instrument in response to the reference following the gas injection or reference signal. Report this value in calibration span units of measure. For all monitors except flow, the units (and decimal precision) should match the hourly reporting. For example, for SO<sub>2</sub>, report concentration in ppm and round the resulting value to the appropriate number of decimal places in Table 4. For flow, use the calibration units of measure defined in the MONITOR SPAN VALUE record and round the resulting value to the appropriate number of decimal places per Table 4.

If the daily calibration was not completed and there was no zero-level injection, leave this field blank.

**Upscale Measured Value**

*Element Name: UpscaleMeasuredValue*

Report the value measured by the instrument in response to the reference following the gas injection or reference signal. Report this value in calibration span units of measure. For all monitors except flow, the units (and decimal precision) should match the hourly reporting. For example, for SO<sub>2</sub>, report concentration in ppm and round the resulting value to the appropriate number of decimal places per Table 4. For flow, use the calibration units of measure defined in the MONITOR SPAN VALUE record and round the resulting value to the appropriate number of decimal places per Table 4.

If the daily calibration was not completed and there was no upscale-level injection, leave this field blank.

**Zero APS Indicator**

*Element Name: ZeroAPSIndicator*

Report whether the zero injection result was determined using a normal specification "0" or the alternative performance specification "1" allowed under Part 75. If the daily calibration was not completed and there was no zero level injection, leave this field blank.

**Upscale APS Indicator**

*Element Name: UpscaleAPSIndicator*

Report whether the upscale injection result was determined using a normal specification "0" or the alternative performance specification "1" allowed under Part 75. If the daily calibration was not completed and there was no upscale-level injection, leave this field blank.

**Zero Calibration Error**

*Element Name: ZeroCalibrationError*

Report the calibration error results of the zero-level injection, as required by Part 75 (see the Upscale Calibration Error element description for further instructions). If the daily calibration was not completed and there was no zero-level injection, leave this field blank.

**Upscale Calibration Error**

*Element Name: UpscaleCalibrationError*

Report the calibration error results of the upscale injection, as required by Part 75. For SO<sub>2</sub>, NO<sub>x</sub>, and flow monitors, express the results either as a percentage of the span value or (for low-emitters of SO<sub>2</sub> or NO<sub>x</sub>, or for low-span differential pressure-type flow monitors) as the absolute value of the difference between the reference and measured values (i.e., |R - A|). For all parameters, except for low-span differential pressure-type flow monitors using the alternative specification, report the calibration error (or |R - A|) to one decimal place. When a low-span differential pressure-type flow monitor uses the alternative specification because the standard specification was not met, the |R - A| value must be reported to two decimal places. If the daily calibration was not completed and there was no upscale-level injection, leave this field blank.

If the calculated calibration error meets the standard specification, report the result as a percentage of the span even though the result would also pass the alternative specification. Only when the result does not pass the standard specification, but meets the alternative specification, should the absolute value of the difference be reported. If the test does not pass either specification, report the result as a percentage of span.

For CO<sub>2</sub> and O<sub>2</sub> monitors, the results are always determined using  $|R - A|$  and are expressed in terms of absolute percent CO<sub>2</sub> or O<sub>2</sub>. Use this method for all diluent gas monitors used for CO<sub>2</sub> reporting and/or NO<sub>x</sub> reporting.

### Zero Reference Value

*Element Name: ZeroReferenceValue*

Report the calibration gas or reference signal value used in this injection. Report the certified (tag) value of the reference calibration gas, in ppm for SO<sub>2</sub> and NO<sub>x</sub>, or in %CO<sub>2</sub> or %O<sub>2</sub> for CO<sub>2</sub> and O<sub>2</sub>. Report the value of the reference signal in the appropriate units, for flow monitors. Report the value to the precision defined in Table 4. If the daily calibration was not completed and there was no zero-level injection, leave this field blank.

### Upscale Reference Value

*Element Name: UpscaleReferenceValue*

Report the calibration gas or reference signal value used in this injection. Report the certified (tag) value of the reference calibration gas, in ppm for SO<sub>2</sub> and NO<sub>x</sub>, or in %CO<sub>2</sub> or %O<sub>2</sub> for CO<sub>2</sub> and O<sub>2</sub>. Report the value of the reference signal in the appropriate units for flow monitors. Report the value to the precision defined in Table 4. If the daily calibration was not completed and there was no upscale-level injection, leave this field blank.

**Table 4**  
**Precision of Reported Values for DAILY CALIBRATION DATA**

Parameter Codes	Number of Decimal Places
CO2, H2O, NOX, O2, SO2	One
FLOW	Same as Span Value

### Upscale Gas Type Code

*Element Name: UpscaleGasTypeCode*

For SO<sub>2</sub>, NO<sub>x</sub>, CO<sub>2</sub>, and O<sub>2</sub> components, report one of the gas type codes in Table 5 to indicate the type of gas in the cylinder used for the upscale injection. Note: If you use a blend of EPA Protocol gases that is not present in this table, you may report a value of "APPVD", but you will need to contact EPA before submitting the data in order to get permission to use this code. Leave this field blank if the Component Type Code is FLOW or H<sub>2</sub>O.

**Table 5**  
**Gas Type Codes and Descriptions**

<b>Code</b>	<b>Description</b>
SO2	EPA Protocol gas standard consisting of a single certified component, SO <sub>2</sub> , and a balance gas
NO	EPA Protocol gas standard consisting of a single certified component, NO, and a balance gas
NO2	EPA Protocol gas standard consisting of a single certified component, NO <sub>2</sub> , and a balance gas
CO2	EPA Protocol gas standard consisting of a single certified component, CO <sub>2</sub> , and a balance gas
O2	EPA Protocol gas standard consisting of a single certified component, O <sub>2</sub> , and a balance gas
SN	EPA Protocol gas bi-blend standard consisting of two certified components, SO <sub>2</sub> and NO, and a balance gas
SN2	EPA Protocol gas bi-blend standard consisting of two certified components, SO <sub>2</sub> and NO <sub>2</sub> , and a balance gas
SC	EPA Protocol gas bi-blend standard consisting of two certified components, SO <sub>2</sub> and CO, and a balance gas
SC2	EPA Protocol gas bi-blend standard consisting of two certified components, SO <sub>2</sub> and CO <sub>2</sub> , and a balance gas
SO	EPA Protocol gas bi-blend standard consisting of two certified components, SO <sub>2</sub> and O <sub>2</sub> , and a balance gas
NX	EPA Protocol gas bi-blend standard consisting of two certified components, NO and NO <sub>2</sub> , and a balance gas
NC	EPA Protocol gas bi-blend standard consisting of two certified components, NO and CO, and a balance gas
NC2	EPA Protocol gas bi-blend standard consisting of two certified components, NO and CO <sub>2</sub> , and a balance gas
N2C	EPA Protocol gas bi-blend standard consisting of two certified components, NO <sub>2</sub> and CO, and a balance gas
N2C2	EPA Protocol gas bi-blend standard consisting of two certified components, NO <sub>2</sub> and CO <sub>2</sub> , and a balance gas
OC	EPA Protocol gas bi-blend standard consisting of two certified components, O <sub>2</sub> and CO, and a balance gas
OC2	EPA Protocol gas bi-blend standard consisting of two certified components, O <sub>2</sub> and CO <sub>2</sub> , and a balance gas
SNX	EPA Protocol gas tri-blend standard consisting of three certified components, SO <sub>2</sub> , NO, and NO <sub>2</sub> , and a balance gas
SNC	EPA Protocol gas tri-blend standard consisting of three certified components, SO <sub>2</sub> , NO, and CO, and a balance gas
SNC2	EPA Protocol gas tri-blend standard consisting of three certified components, SO <sub>2</sub> , NO, and CO <sub>2</sub> , and a balance gas

(cont.)

**Table 5**  
**Gas Type Codes and Descriptions (cont.)**

<b>Code</b>	<b>Description</b>
SN2C	EPA Protocol gas tri-blend standard consisting of three certified components, SO <sub>2</sub> , NO <sub>2</sub> , and CO, and a balance gas
SN2C2	EPA Protocol gas tri-blend standard consisting of three certified components, SO <sub>2</sub> , NO <sub>2</sub> , and CO <sub>2</sub> , and a balance gas
SOC	EPA Protocol gas tri-blend standard consisting of three certified components, SO <sub>2</sub> , O <sub>2</sub> , and CO, and a balance gas
NCC	EPA Protocol gas tri-blend standard consisting of three certified components, NO, CO, and CO <sub>2</sub> , and a balance gas
N2CC	EPA Protocol gas tri-blend standard consisting of three certified components, NO <sub>2</sub> , CO, and CO <sub>2</sub> , and a balance gas
NXC	EPA Protocol gas tri-blend standard consisting of three certified components, NO, NO <sub>2</sub> , and CO, and a balance gas
NXC2	EPA Protocol gas tri-blend standard consisting of three certified components, NO, NO <sub>2</sub> , and CO <sub>2</sub> , and a balance gas
OCC	EPA Protocol gas tri-blend standard consisting of three certified components, O <sub>2</sub> , CO, and CO <sub>2</sub> , and a balance gas
SNXC	EPA Protocol gas quad-blend standard consisting of four certified components, SO <sub>2</sub> , NO, NO <sub>2</sub> , and CO, and a balance gas
SNXC2	EPA Protocol gas quad-blend standard consisting of four certified components, SO <sub>2</sub> , NO, NO <sub>2</sub> , and CO <sub>2</sub> , and a balance gas
SNCC	EPA Protocol gas quad-blend standard consisting of four certified components, SO <sub>2</sub> , NO, CO, and CO <sub>2</sub> , and a balance gas
SN2CC	EPA Protocol gas quad-blend standard consisting of four certified components, SO <sub>2</sub> , NO <sub>2</sub> , CO, and CO <sub>2</sub> , and a balance gas
NXCC	EPA Protocol gas quad-blend standard consisting of four certified components, NO, NO <sub>2</sub> , CO, and CO <sub>2</sub> , and a balance gas
SNXCC	EPA Protocol gas quint-blend standard consisting of five certified components, SO <sub>2</sub> , NO, NO <sub>2</sub> , CO, and CO <sub>2</sub> , and a balance gas
APPVD	Other EPA-approved EPA Protocol gas blend (see note below)
AIR	Purified air material
SRM	Standard reference material
NTRM	NIST-traceable reference material
GMIS	Gas manufacturer's intermediate standard
RGM	Research gas mixture
PRM	SRM-equivalent compressed gas primary reference material

Note: If you use a blend of EPA Protocol gases that is not present in this table, you may report a value of "APPVD", but you will need to contact EPA before submitting the data in order to get permission to use this code.

**Cylinder Identifier**

*Element Name: CylinderIdentifier*

For SO<sub>2</sub>, NO<sub>x</sub>, CO<sub>2</sub>, and O<sub>2</sub> components, report the vendor-assigned identification or serial number found on the cylinder used for the upscale injection. Leave this field blank if the Component Type Code is FLOW or H<sub>2</sub>O.

**Vendor Identifier**

*Element Name: VendorIdentifier*

For an EPA Protocol gas, report the EPA-assigned PGVP Vendor ID of the production site that supplied the cylinder used for the upscale injection. An up-to-date list of PGVP Vendor IDs will be located on the EPA website, and can be accessed via the ECMPS Support website. Report "NONPGVP" if the cylinder was purchased from a non-participating vendor prior to 60 days after the rule is published in the FR. Leave this field blank if the Component Type Code is FLOW or H<sub>2</sub>O or if the Gas Type Code is AIR, SRM, NTRM, GMIS, RGM, or PRM.

**Expiration Date**

*Element Name: Expiration Date*

For an EPA Protocol gas, report the expiration date of the cylinder used for the upscale injection. Leave this field blank if the Component Type Code is FLOW or H<sub>2</sub>O or if the Gas Type Code is AIR, SRM, NTRM, GMIS, RGM, or PRM.

***Specific Considerations*****Maintenance Procedures**

- During maintenance procedures, the calibration gas injections used during those procedures do not have to be reported if the results of the calibration gas injection do not indicate that the control status of the monitor has changed. For instance, if a monitoring system is already out-of-control and calibration gases are injected as part of the maintenance procedures, the results of these injections do not have to be reported. Only the results of the post-maintenance calibration error test which is used to validate the subsequent emissions data must be reported. Similarly, if as part of a maintenance procedure on one monitor, calibration gases must be injected into other monitors, the results of these injections do not have to be reported as long as they are within the calibration error specification. If the results of these injections indicate that any monitoring system is out-of-control, these injections must be reported and considered to be a failed calibration error test.

**Components Belonging to Multiple Systems**

- If a component is part of two (or more) systems (for example, a CO<sub>2</sub> analyzer used both as a primary CO<sub>2</sub> monitor and as a diluent monitor in a NO<sub>x</sub>-diluent monitoring system) the calibration error test should only be reported once, using the component ID. Data validation for each monitoring system which the component is part of will be determined based on this single test record.

**Moisture Monitoring Systems**

- For moisture monitoring systems consisting of wet- and dry-basis O<sub>2</sub> monitors, report two calibrations only if the wet and dry readings are obtained from two different analyzers. Report only the dry-basis O<sub>2</sub> calibration when a single analyzer is used for both wet and dry oxygen.

**Flow Monitoring Systems**

- For flow monitoring systems comprised of two flow components, perform and report a daily calibration for each flow component in the system.

**Dual Range Monitors**

- For dual range monitors, perform and report daily calibrations for the instrument range(s) used during the day.

**Provisions for Conducting Daily Calibration**

- Conduct the daily calibration according to the requirements of 40 CFR Part 75, Appendices A and B. Daily calibrations validate the acceptability of emissions data from each monitoring component.

## 2.3 DAILY EMISSIONS DATA

### DAILY EMISSIONS DATA XML Model

**Figure 6**  
**DAILY EMISSION DATA XML Elements**

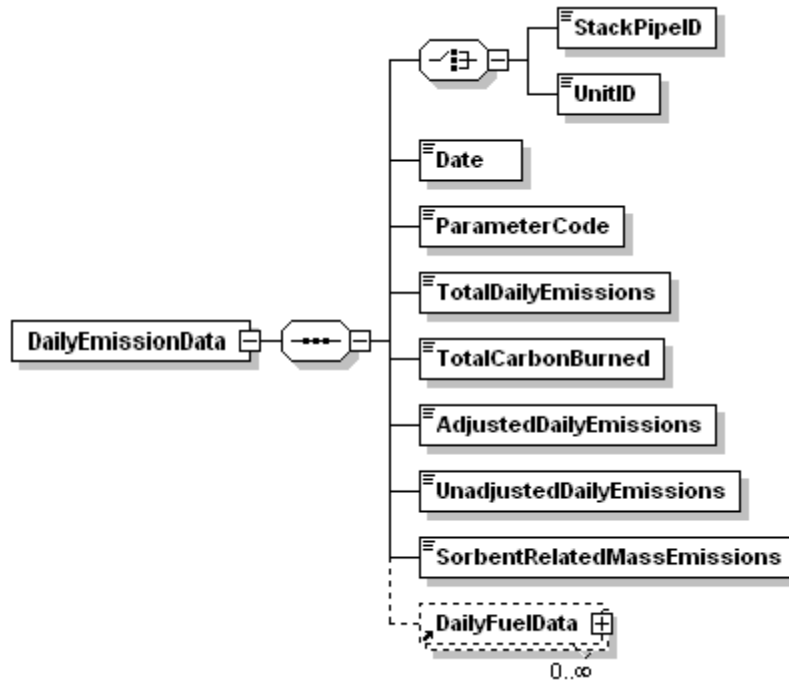

### DAILY EMISSIONS DATA Overview

#### Description of Data

Submit DAILY EMISSION DATA records to report daily CO<sub>2</sub> mass determined using Appendix G Fuel Sampling and Analysis (FSA) and Equation G-1. Note that this CO<sub>2</sub> value is the total mass emissions for the day, not a daily rate.

#### DAILY EMISSIONS DATA XML Elements

Instructions for completing each element of the DAILY EMISSION DATA Elements section are provided below:

#### Unit ID or Stack Pipe ID

*Element Name:* *UnitID* or *StackPipeID*

Report either the Unit ID or Stack Pipe ID for the daily emissions location. This is the alphanumeric code assigned by a source to identify a unit or pipe.

**Date***Element Name: Date*

Report the date corresponding to the daily emissions.

**Parameter Code***Element Name: ParameterCode*

Report the parameter code for daily emissions monitoring as CO2M.

**Total Daily Emissions***Element Name: TotalDailyEmissions*

Report the total CO<sub>2</sub> mass emissions for the day in tons. Round to one decimal place.

**Total Carbon Burned***Element Name: TotalCarbonBurned*

Report the total amount of carbon burned (in lbs) during the day.

**Adjusted Daily Emissions***Element Name: AdjustedDailyEmissions*

This field applies only to coal-fired units and is optional. Report the adjusted value, in tons, if adjusting the CO<sub>2</sub> mass emissions for carbon content of the flyash. Round to one decimal place.

Leave this field blank if electing not to make an adjustment for the carbon content of the flyash.

**Unadjusted Daily Emissions***Element Name: UnadjustedDailyEmissions*

Report the unadjusted daily emissions value determined using the G-1 equation.

**Sorbent Related Mass Emissions***Element Name: SorbentRelatedMassEmissions*

This field is only for units with add-on SO<sub>2</sub> emission controls. Report data in this field in tons. Round to one decimal place.

## 2.3.1 DAILY FUEL DATA

### DAILY FUEL DATA XML Model

**Figure 7**  
**DAILY FUEL DATA XML Elements**

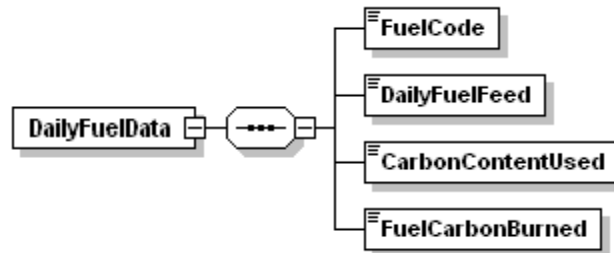

### DAILY FUEL DATA Overview

#### Description of Data

Submit Daily Fuel Data records to report fuel-specific data used when using Appendix G Fuel Sampling and Analysis (FSA) and Equation G-1 to determine daily CO<sub>2</sub> mass if required to do so on behalf of the RGGI program.

### DAILY FUEL DATA XML Elements

#### Fuel Code

*Element Name: FuelCode*

Report the fuel code of a specific fuel used during the day.

#### Daily Fuel Feed

*Element Name: DailyFuelFeed*

Report the feed rate of a specific fuel (in lbs) used during the day.

#### CarbonContent Used

*Element Name: CarbonContentUsed*

Report the amount of carbon burned as a percentage of the daily feed rate for a specific fuel.

#### Fuel Carbon Burned

*Element Name: FuelCarbonBurned*

Report the amount of carbon burned (in lbs) during the day for a specific fuel.

## 2.4 HOURLY OPERATING DATA

### HOURLY OPERATING DATA XML Model

**Figure 8**  
**HOURLY OPERATING DATA XML Elements**

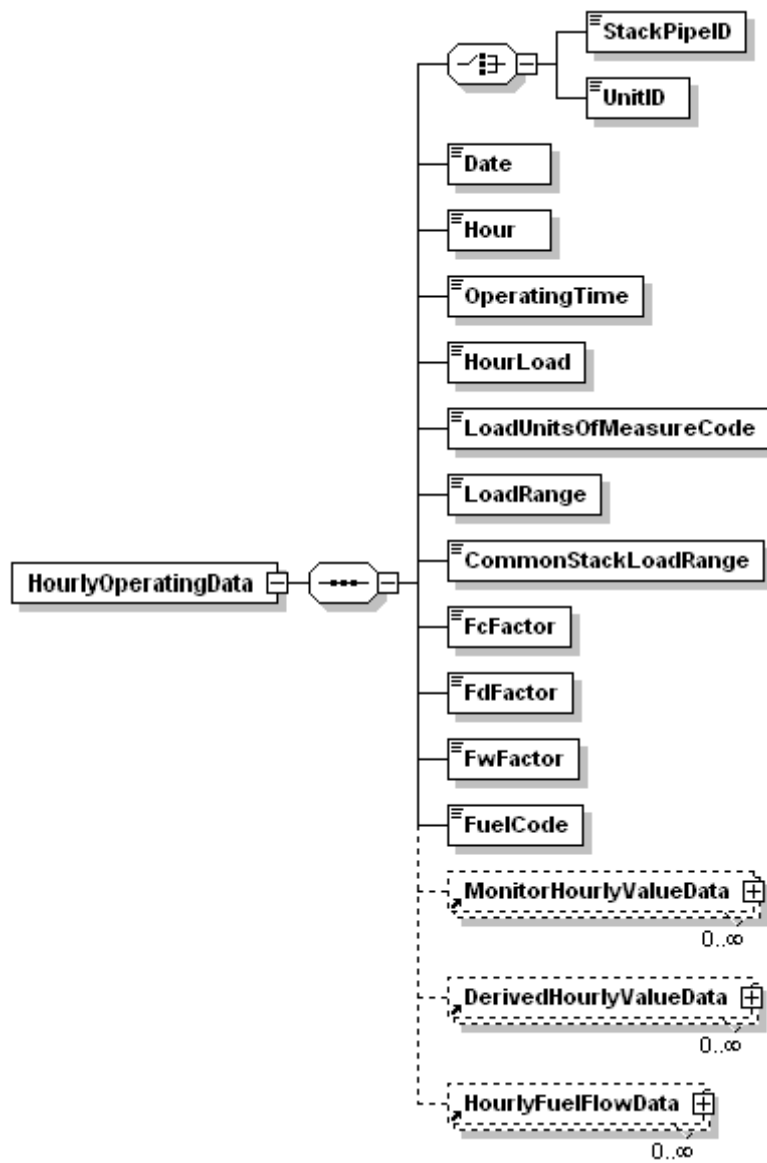

### HOURLY OPERATING DATA Overview

#### Description of Data

Report an HOURLY OPERATING DATA record for every clock hour of the reporting period for every unit, stack, and pipe in the monitoring configuration represented by this emissions file. (You must report these records even for non-operating quarters.) Report an HOURLY OPERATING DATA record for every clock hour, as follows: (a) for each affected unit, irrespective of the location(s) at which the emissions are measured; and (b) for each common stack (or pipe) or multiple stack (or pipe) location at which emissions are measured.

For example, if common stack CS1 serves Units 1 and 2 and emissions are monitored at the common stack, report HOURLY OPERATING DATA for the common stack and also report HOURLY OPERATING DATA for each unit. As a second example, if Unit 1 discharges through two stacks, MS1 and MS2, and emissions are monitored at each stack, report separate HOURLY OPERATING DATA for each stack and also report HOURLY OPERATING DATA for Unit 1.

If a common stack serves Units 1, 2, and 3, but Unit 1 did not operate during the quarter, report HOURLY OPERATING DATA for every clock hour in the quarter for Unit 1 with 0.00 as the operating time and leave the remaining fields blank. The HOURLY OPERATING DATA records for Units 2 and 3 will contain the appropriate operating data.

## HOURLY OPERATING DATA XML Elements

### Unit ID or Stack Pipe ID

*Element Name: UnitID or StackPipeID*

Report either the Unit ID or Stack Pipe ID for the HOURLY OPERATING DATA. This is the alphanumeric code assigned by a source to identify a unit, stack, or pipe.

### Date

*Element Name: Date*

Report the date corresponding to the data being reported.

### Hour

*Element Name: Hour*

Report the hour corresponding to the data being reported.

### Operating Time

*Element Name: OperatingTime*

Report the fraction of the clock hour during which the unit combusted any fuel (or the fraction of the clock hour during which the stack or pipe was used). You may use any equal increments from hundredths (0.01 hr) to quarters (0.25 hr) of an hour.

If the unit, stack, or pipe did not operate, report "0.00." For common stack and multiple stack configurations, report an operating time of "0.00" in the HOURLY OPERATING DATA record for any clock hour in which none of the units that exhaust through a particular stack are operating or for any clock hour in which the dampers are closed so that flue gas is unable to pass through the stack.

If you elect to use a multiple-stack configuration to report NO<sub>x</sub> emissions data from a combined-cycle combustion turbine that: (a) uses Appendix D to measure the unit-level heat input; and (b) has a NO<sub>x</sub>-diluent monitoring system installed on each stack (i.e., on the main stack and the bypass stack), report the stack operating times as follows:

- For any hour in which all of the exhaust gases flow through one stack or the other, the operating time for the stack that is in use will be equal to the unit operating time for that hour, and the operating time for the other stack will be 0.00; and
- For a transition hour, in which gases flow through both stacks during the entire hour or any part of the hour:
  - Report that fraction of the hour (if any) in which gases flow only through the main stack as the "main stack operating time;" and
  - Report the remainder of the hour in which gases either flow through both stacks simultaneously or flow only through the bypass stack as the "bypass stack operating time."

#### Operating Time for LME Units

Report the fraction of the clock hour during which the unit combusted any fuel (or the fraction of the clock hour during which the stack or pipe was used).

Report a unit operating time of "0.00" for any clock hour in which the unit did not operate.

#### **Hour Load**

*Element Name: HourLoad*

Report hourly load information as either steam load or gross unit load. The units for average hourly gross unit load are megawatts and the units for steam load are 1,000 lbs/hr or mmBtu/hr. Note that these values are rates and must be multiplied by operating time to yield the output for an hour. Do not correct steam load for standard temperature and pressure; use steam load at measured temperature and pressure (see Part 75, Appendix C, Section 2.2.1).

If you convert auxiliary heat input to the megawatts equivalent (e.g., for a heat recovery steam generator with a duct burner) and add that value to megawatts for a gas turbine, you should report the unit electric load in megawatts.

For all multiple-stack configurations, for each unit operating hour in which gases flow through a particular stack or duct, report the unit load in both the stack-level and unit-level HOURLY OPERATING DATA records for that hour.

For monitored common stacks, report the weighted sum of the hourly unit loads for all units that exhaust through the stack, according to the following formula:

$$\text{Weighted Load} = \frac{\sum (\text{Load}_u \times \text{OpTime}_u)}{\text{OpTime}_{cs}}$$

Leave this element blank (do not report zeros) for any clock hour in which the unit, stack, or pipe did not operate. Also leave this element blank for units that do not produce electrical or steam load (e.g., cement kilns, refinery process heaters, etc.).

### Load Units of Measure Code

*Element Name:* *LoadUnitsOfMeasureCode*

Report the appropriate code to identify the load units of measure.

**Table 6**  
**Load Units of Measure Codes and Descriptions**

Code	Description
MW	Megawatt
KLBHR	1,000 Pounds Steam Load per Hour
MMBTUHR	Steam Load in mmBtu per Hour

Leave this element blank for any clock hour in which the unit, stack, or pipe did not operate. Also leave this element blank for units that do not produce electrical or steam load (e.g., cement kilns, refinery process heaters, etc.).

### Load Range

*Element Name:* *LoadRange*

Report an operating load range (load bin number) for each operating hour (see Appendix C to Part 75) for units that produce electrical or steam load. For units that do not produce electrical or steam load (e.g., cement kilns, refinery process heaters, etc.), report the operational bin number, if operational bins are used for missing data purposes. If the operational bin number is indeterminable, report "0."

For a monitored common stack, the load bins are defined at the common stack on the basis of combined unit load, and load-based missing data routines are applied at the common stack. Therefore for each unit operating hour, report the common stack load bin number in both the common stack and unit-level HOURLY OPERATING DATA records.

For a multiple-stack configuration in which gases normally flow through both stacks or ducts simultaneously (e.g., a twin-stack or split-breeching configuration), the load bins are set up on

the basis of unit load. Therefore, for each unit operating hour, report the unit load bin number in both the unit-level and stack-level HOURLY OPERATING DATA records.

For load-based units, leave this element blank (do not report zeros) for any clock hour in which the unit does not operate or gases do not flow through the stack (as applicable). Also leave this element blank for non load-based units that do not use operational bins for missing data purposes and for LME units.

### **Common Stack Load Range**

*Element Name: CommonStackLoadRange*

For a common stack with installed stack flow monitor, if you have elected to establish 20 load bins for missing data substitution purposes, report the appropriate load bin number using this element. Note that this is an optional alternative to the standard load range.

### **Fc Factor**

*Element Name: FcFactor*

If any emissions calculations at this location require use of the carbon-based F-factor, report the appropriate Fc-factor value corresponding to the fuel(s) burned during the hour.

### **Fd Factor**

*Element Name: FdFactor*

If any emissions calculations at this location require use of the dry-basis F-factor, report the appropriate Fd-factor value corresponding to the fuel(s) burned during the hour.

### **Fw Factor**

*Element Name: FwFactor*

If any emissions calculations at this location require use of the wet-basis F-factor, report the appropriate Fw-factor value corresponding to fuel(s) burned during the hour.

### **Fuel Code**

*Element Name: FuelCode*

You must report data in this field if: (1) you have elected to use the fuel-specific continuous emissions monitoring system (CEMS) missing data option under §75.33; or (2) you have an exhaust configuration consisting of a monitored main stack and an unmonitored bypass stack, and you opt to report the fuel-specific Maximum Potential Concentration (MPC) or maximum potential NO<sub>x</sub> emission rate (MER) value during bypass hours (see §§75.16, 75.17 and 75.72). Otherwise, reporting data in this field is optional. Select one Fuel Code shown in Table 7.

**Table 7  
Fuel Codes and Descriptions**

<b>Code</b>	<b>Description</b>
MIX	Use this code for any hour in which fuels are co-fired
BFG	Blast Furnace Gas
BUT	Butane (if measured as a gas)
C	Coal
CDG	Coal-Derived Gas
COG	Coke Oven Gas
CRF	Coal Refuse (culm or gob)
DGG	Digester Gas
DSL	Diesel Oil
LFG	Landfill Gas
LPG	Liquefied Petroleum Gas (as defined in §72.2)
NNG	Natural Gas
OGS	Other Gas
OIL	Residual Oil
OOL	Other Oil
OSF	Other Solid Fuel
PDG	Producer Gas
PNG	Pipeline Natural Gas (as defined in §72.2)
PRG	Process Gas
PRP	Propane (if measured as a gas)
PRS	Process Sludge
PTC	Petroleum Coke
R	Refuse
RFG	Refinery Gas
SRG	Unrefined Sour Gas
TDF	Tire-Derived Fuel
W	Wood
WL	Waste Liquid

## 2.4.1 MONITOR HOURLY VALUE DATA

### MONITOR HOURLY VALUE DATA XML Model

**Figure 9**  
**MONITOR HOURLY VALUE DATA XML Elements**

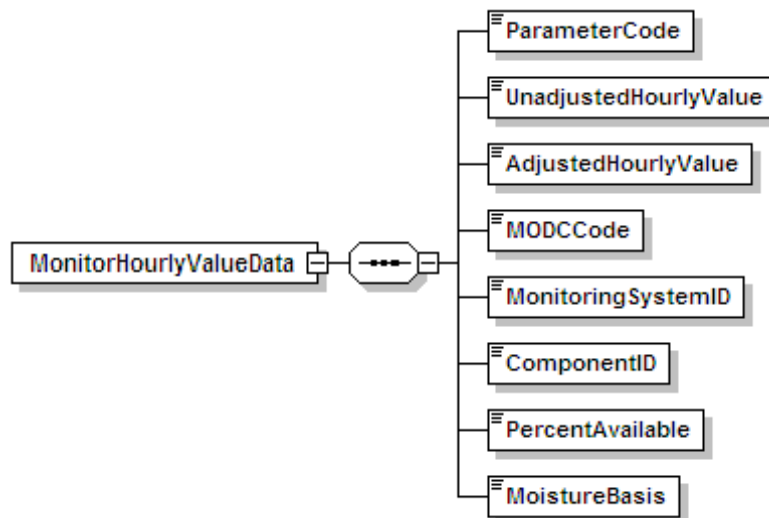

### MONITOR HOURLY VALUE DATA Overview

#### Description of Data

Use the MONITOR HOURLY VALUE DATA (MHV) record to report each value measured by a continuous emissions or stack flow monitoring system (or, if applicable, the missing data substitution value for the parameter). The monitored emission values can include SO<sub>2</sub> concentration, NO<sub>x</sub> concentration, CO<sub>2</sub> concentration, O<sub>2</sub> concentration, H<sub>2</sub>O concentration (moisture), and volumetric flow. These instructions contain subsections of each measured parameter, to give specific stipulations on how to report for that particular parameter.

#### SO<sub>2</sub> Concentration

If you use continuous emissions monitoring systems (CEMS) to determine SO<sub>2</sub> mass emissions, report SO<sub>2</sub> concentration in an MHV record for each hour or partial hour of unit operation, with one exception: do not report an MHV record for hours in which only gaseous fuel is combusted, if you account for SO<sub>2</sub> mass emissions during those hours using the provisions of §75.11(e)(1) in lieu of operating and recording data from the SO<sub>2</sub> monitoring system.

#### Volumetric Flow

If you use stack flow monitoring to determine hourly heat input rate or SO<sub>2</sub>, CO<sub>2</sub>, or NO<sub>x</sub> mass emissions, report volumetric flow in an MHV record for each operating hour or partial operating hour.

Table 8, below, summarizes which elements to report for SO<sub>2</sub>C and FLOW MHV records.

**Table 8**  
**MHV Elements for SO<sub>2</sub>C or Flow**

MHV Elements to Report	SO <sub>2</sub> C or Flow	
	Measured Data	Missing Data
Parameter Code	✓	✓
Unadjusted Hourly Value	✓	
Adjusted Hourly Value	✓	✓
Method of Determination Code (MODC)	✓	✓
Monitoring System ID	✓	
Component ID	✓	
Percent Available	✓	✓
Moisture Basis		

### NO<sub>x</sub> Concentration

If you use a NO<sub>x</sub>-diluent monitoring system to determine and report the NO<sub>x</sub> emission rate and/or a NO<sub>x</sub> concentration monitor in conjunction with Stack Flow to determine NO<sub>x</sub> mass, report an MHV record, as follows, for NO<sub>x</sub>C for each unit or stack operating hour as needed for those determinations.

(a) Monitoring locations with only a NO<sub>x</sub>-diluent monitoring system:

Report the NO<sub>x</sub>C MHV record only for hours in which a quality-assured NO<sub>x</sub> concentration is available and a quality-assured diluent gas (CO<sub>2</sub> or O<sub>2</sub>) concentration is available. (Whenever either the NO<sub>x</sub> concentration or diluent concentration is missing for an hour, report the appropriate substitute data value for NO<sub>x</sub> emission rate in the DERIVED HOURLY VALUE (DHV) record and do not report an MHV record.)

The elements to report for (a) are summarized in Table 9.

**Table 9**  
**MHV Elements for NOXC Record -- NOX Rate System Only**

MHV Elements to Report	NOXC MHV Record	
	Measured Data	Missing Data
Parameter Code	✓	NA
Unadjusted Hourly Value	✓	NA
Adjusted Hourly Value		NA
MODC	✓	NA
Monitoring System ID		NA
Component ID	✓	NA
Percent Available		NA
Moisture Basis		NA

(b) Monitoring locations with only a NO<sub>x</sub> concentration monitoring system:

Report the NOXC MHV record for every operating hour. If a valid NO<sub>x</sub> concentration is not obtained for the hour, report substitute data in the Adjusted Hourly Value element of the record using the applicable missing data procedures for NOXC.

(c) Monitoring locations with both a NO<sub>x</sub>-diluent and a NO<sub>x</sub> concentration monitoring system:

Report the NOXC MHV record for every operating hour using the Monitoring System ID for the NO<sub>x</sub> concentration monitoring system. If a valid NO<sub>x</sub> concentration is not obtained for the hour, report the applicable substitute NO<sub>x</sub> concentration data in the MHV record using the applicable missing data procedures for NOXC; and report the appropriate substitute data value for NO<sub>x</sub> emission rate in the DHV record.

The elements to report for (b) and (c) are summarized in Table 10 below.

**Table 10**  
**MHV Elements for NOXC Record -- NOXC System**

MHV Elements to Report	NOXC MHV Record	
	Measured Data	Missing Data
Parameter Code	✓	✓
Unadjusted Hourly Value	✓	
Adjusted Hourly Value	✓	✓
MODC	✓	✓
Monitoring System ID	✓ <sup>1</sup>	
Component ID	✓	
Percent Available	✓	✓
Moisture Basis		

<sup>1</sup> Report the NOXC System ID.

Note that for units with add-on NO<sub>x</sub> emission controls, hours in which the flue gases are discharged through an unmonitored bypass stack are considered to be missing data hours. However, when the outlet NO<sub>x</sub> monitor is unavailable and proper operation of the emission controls is not verified, §75.34 (a)(1) allows you to report data from a certified NO<sub>x</sub> monitor at the control device inlet. If you choose this option, these hours are treated as "available" hours for the purposes of the missing data lookbacks and percent monitor data availability (PMA) calculations.

For a summary of these requirements, see Table 11 below.

#### Reporting of High Range and Full Scale Exceedance Defaults

Treat any hour(s) in which a default high range value (200 percent of Maximum Potential Concentration (MPC)) or a full scale exceedance value (200 percent of range) is used in the calculation of the hourly average NO<sub>x</sub> concentration as follows:

(a) For NO<sub>x</sub> concentration monitoring systems:

Treat these hours as quality-assured monitor operating hours and include them in missing data lookback and as available hours for percent monitor data availability calculations.

(b) For NO<sub>x</sub>-diluent monitoring systems:

1. If a quality-assured diluent value is available for the hour, treat the hour as quality-assured data and use the appropriate NO<sub>x</sub> concentration value in conjunction with the quality-assured average diluent gas concentration for the hour to calculate and report NO<sub>x</sub> emission rate in the DHV record.
2. If a quality-assured diluent gas concentration is not available for the hour, then consider the NO<sub>x</sub> emission rate data for the hour to be missing and do not report any MHV record for the hour. Instead, report the maximum potential NO<sub>x</sub> emission rate (MER) as a substitute data value in a DHV record using an MODC of 25.

(c) Where both NO<sub>x</sub> concentration and NO<sub>x</sub>-diluent monitoring systems are identified:

1. If a quality-assured diluent value is available for the hour, treat the hour as a quality-assured monitor operating hour and include it in the missing data lookback and as an available hour for percent monitor data availability calculations. Also, use the NO<sub>x</sub> concentration value in conjunction with the quality-assured average diluent gas concentration for the hour to calculate and report NO<sub>x</sub> emission rate in the DHV record.
2. If a quality-assured diluent gas concentration is not available for the hour, treat the hour as a quality-assured monitor operating hour for NO<sub>x</sub> and include it in the missing data lookback for NO<sub>x</sub> and as an available hour for percent monitor data availability calculations for the NO<sub>x</sub> system. However, the NO<sub>x</sub> emission rate data for the hour is considered to be missing. Report the MER as a substitute data value in a DHV record using an MODC of 25.

**Table 11**  
**Summary of NO<sub>x</sub> MONITOR HOURLY VALUE Record Reporting Requirements**

Use of NO <sub>x</sub> Analyzer	Monitoring System ID Used	Missing Data Instructions
For NO <sub>x</sub> emission rate only	Blank	Do not report an MHV record for the hour. Perform NO <sub>x</sub> missing data substitution in DHV record (if NO <sub>x</sub> or diluent concentration is unavailable).
For NO <sub>x</sub> mass calculation using NO <sub>x</sub> concentration x stack flow	NO <sub>x</sub> concentration monitoring System ID	Perform missing data substitution for NO <sub>x</sub> concentration in an MHV record.
Both NO <sub>x</sub> emission rate and NO <sub>x</sub> mass calculation using NO <sub>x</sub> concentration x stack flow	NO <sub>x</sub> concentration monitoring System ID	Perform missing data substitution for NO <sub>x</sub> concentration in an MHV record. Also perform missing data substitution in the DHV record for NO <sub>x</sub> emission rate if either the NO <sub>x</sub> or diluent concentration is missing.

CO<sub>2</sub> Concentration

Report a MHV record for CO<sub>2</sub> Concentration only if you use a CO<sub>2</sub> analyzer to determine CO<sub>2</sub> concentration. If you use an O<sub>2</sub> concentration monitor and Equation F-14a or F-14b to determine CO<sub>2</sub> concentration for each hour, report a MHV record for O<sub>2</sub> concentration for the hour (see the instructions for O<sub>2</sub> Concentration below) and report the calculated CO<sub>2</sub> concentration in a DHV record.

If you use a CO<sub>2</sub> analyzer reading to calculate NO<sub>x</sub> emission rate, CO<sub>2</sub> mass emission rate, and/or Heat Input, report a MHV record for CO<sub>2</sub>C for each unit or stack operating hour as needed for those determinations.

**Table 12**  
**MHV Elements for CO<sub>2</sub>C**

MHV Elements to Report	CO <sub>2</sub> C MHV Records	
	Measured Data	Missing Data <sup>3</sup>
Parameter Code	✓	✓
Unadjusted Hourly Value	✓	✓
Adjusted Hourly Value		
MODC	✓	✓
Monitoring System ID	1	
Component ID	✓	
Percent Available	2	✓
Moisture Basis		

<sup>1</sup> If the CO<sub>2</sub> component is part of a CO<sub>2</sub> system, report the CO<sub>2</sub> System ID. Otherwise, leave the System ID blank.

<sup>2</sup> If the CO<sub>2</sub> is used to calculate heat input or CO<sub>2</sub> mass rate, report the Percent Available value for every operating hour.

<sup>3</sup> If the CO<sub>2</sub> value is used to calculate heat input or CO<sub>2</sub> mass rate, report an MHV record for CO<sub>2</sub>C for every operating hour. Otherwise, do not report CO<sub>2</sub>C MHV records for missing data hours.

- (a) Whenever you use a CO<sub>2</sub> monitor to determine CO<sub>2</sub> mass emissions and/or for heat input rate:

Report a MHV record using the CO<sub>2</sub> Monitoring System ID, for each hour or partial hour of unit operation. When the hourly CO<sub>2</sub> concentration is missing, or for hours in which the flue gases are discharged through an unmonitored bypass stack, use the missing data routines in §75.35 and 75.36 to provide substitute data values.

If the CO<sub>2</sub> monitor is also used as the diluent monitor for a NO<sub>x</sub>-diluent monitoring system, whenever a CO<sub>2</sub> RATA is failed on the CO<sub>2</sub> monitoring system, then both the CO<sub>2</sub> and NO<sub>x</sub>-diluent monitoring systems are considered out-of-control. (See Appendix B §2.3.2(g)). Report the applicable substitute CO<sub>2</sub> concentration data in the MHV record using the applicable missing data procedures for CO<sub>2</sub>C. For NO<sub>x</sub> emission rate, report the appropriate substitute data value in the DHV record.

However, if the CO<sub>2</sub> data for the CO<sub>2</sub> monitoring system is considered out-of-control due to the expiration of the applicable CO<sub>2</sub> RATA but the NO<sub>x</sub> RATA has not yet expired,<sup>1</sup> then substitute data should only be used for CO<sub>2</sub> mass and heat input rate calculations and not for calculation of the NO<sub>x</sub> emission rate. For NO<sub>x</sub> emission rate, the actual measured CO<sub>2</sub> concentration should be used. In such cases, report two CO<sub>2</sub> concentrations for each hour until a CO<sub>2</sub> RATA is completed. First, report the appropriate substitute CO<sub>2</sub> data using the CO<sub>2</sub> System ID. Second, report the actual CO<sub>2</sub> value recorded by the CO<sub>2</sub> component, leaving the System ID blank. (The actual CO<sub>2</sub> value will be used in the NO<sub>x</sub> emission rate calculation for the hour, while the substitute data value will be used in the CO<sub>2</sub> mass and heat input rate calculations.)

- (b) If you use the CO<sub>2</sub> monitor only to calculate NO<sub>x</sub> emission rate:

Report an MHV record for CO<sub>2</sub> concentration. Leave the Monitoring System ID blank. Do not report an MHV record for the hour if: (1) a quality-assured CO<sub>2</sub> concentration is not available; or (2) a quality-assured NO<sub>x</sub> concentration is not available; or (3) both (1) and (2). Instead, report a substitute data value for NO<sub>x</sub> emission rate in the DHV record.

Note that hours in which the flue gases are discharged through an unmonitored bypass stack are considered to be missing data hours. For these hours, do not report a MHV record. In the DHV record, report the NO<sub>x</sub> MER and MODC of "23."

When a default high range value (200 percent of MPC) or a full-scale exceedance value (200 percent of the range) is used in the calculation of the hourly average NO<sub>x</sub> concentration, the NO<sub>x</sub> concentration is considered to be both quality-assured and available. Therefore, if a quality-assured CO<sub>2</sub> concentration is available for that hour, report a MHV record and calculate the NO<sub>x</sub> emission rate in the usual manner. However, if a quality-assured CO<sub>2</sub> concentration is not available for that hour, the NO<sub>x</sub> emission rate data for the hour are considered missing. In that case, do not report a MHV record for the hour and report the maximum potential NO<sub>x</sub> emission rate (MER) as a substitute data value in DHV record, using an MODC of "25."

### O<sub>2</sub> Concentration

Report an MHV record for O<sub>2</sub> concentration for each hour in which you use the O<sub>2</sub> concentration to determine the hourly NO<sub>x</sub> emission rate, heat input rate, or CO<sub>2</sub> concentration. Report two MHV records for O<sub>2</sub> concentration (one wet-basis and one dry-basis) for each hour in which you use O<sub>2</sub> concentration to determine percent moisture.

<sup>1</sup> Note that this situation should only arise if the NO<sub>x</sub> emission rate RATA was done using O<sub>2</sub> as the diluent for the reference method or if the CO<sub>2</sub> RATA data are not submitted. If the RATA was conducted using a CO<sub>2</sub> diluent in the reference method, then there should be sufficient CO<sub>2</sub> data available to submit a RATA for the CO<sub>2</sub> system.

If the O<sub>2</sub> value is used for the heat input calculation, report the MHV record for O<sub>2</sub> for every operating hour and use the appropriate substitute data for any operating hour in which a quality-assured O<sub>2</sub> value is not obtained. Otherwise, report the MHV record only for hours in which a quality-assured O<sub>2</sub> value is obtained.

**Table 13**  
**MHV Elements for O2C**

MHV Elements to Report	O2C MHV Records	
	Measured Data	Missing Data <sup>4</sup>
Parameter Code	✓	✓
Unadjusted Hourly Value	✓	✓
Adjusted Hourly Value		
MODC	✓	✓
Monitoring System ID	1	
Component ID	✓	
Percent Available	2	✓
Moisture Basis	3	

<sup>1</sup> If the O<sub>2</sub> component is part of a CO<sub>2</sub> system, report the CO<sub>2</sub> System ID. If the O<sub>2</sub> component is part of an O<sub>2</sub> system, report the O<sub>2</sub> System ID. Otherwise, leave the System ID blank.

<sup>2</sup> If the O<sub>2</sub> value is used to calculate heat input, report the Percent Available value for every operating hour.

<sup>3</sup> If the O<sub>2</sub> value is used to calculate H<sub>2</sub>O, report the Moisture basis. Otherwise, leave this field blank.

<sup>4</sup> If the O<sub>2</sub> value is used to calculate heat input, report an MHV record for O2C for every operating hour. Otherwise, do not report O2C MHV records for missing data hours.

- (a) Whenever you use an O<sub>2</sub> monitor to determine CO<sub>2</sub> concentration, CO<sub>2</sub> mass emissions, and/or for heat input rate (as part of a CO<sub>2</sub> monitoring system):

Report an MHV record using the CO<sub>2</sub> Monitoring System ID, for each hour or partial hour of unit operation in which a quality-assured O<sub>2</sub> value is obtained. When the hourly O<sub>2</sub> concentration is missing, or for hours in which the flue gases are discharged through an unmonitored bypass stack, use the missing data routines in §75.36 to provide substitute data values if the O<sub>2</sub> value is used to determine heat input.

If the O<sub>2</sub> monitor is also used as the diluent monitor for a NO<sub>x</sub>-diluent monitoring system, whenever a CO<sub>2</sub> RATA is failed on the CO<sub>2</sub> monitoring system, then the CO<sub>2</sub>, and NO<sub>x</sub>-diluent monitoring systems (as applicable) are each considered to be out-of-control. (See Appendix B §2.3.2(g).) If heat input is calculated from the O<sub>2</sub>, report the

applicable substitute O<sub>2</sub> concentration data in the MHV record using the applicable missing data procedures for O<sub>2</sub>C. For CO<sub>2</sub> concentration, CO<sub>2</sub> mass, and NO<sub>x</sub> emission rate, report the appropriate substitute data values in the appropriate DHV records. However, if the O<sub>2</sub> data for the CO<sub>2</sub> monitoring system is considered out-of-control due to the expiration of the applicable CO<sub>2</sub> RATA but the NO<sub>x</sub> RATA has not yet expired,<sup>2</sup> then substitute data should only be used for CO<sub>2</sub> concentration and heat input rate calculations and not for calculation of the NO<sub>x</sub> emission rate. The actual measured O<sub>2</sub> concentration should be used to calculate NO<sub>x</sub> emission rate. In such cases, report two O<sub>2</sub> concentrations for each hour until a CO<sub>2</sub> RATA is completed. First, report the appropriate substitute O<sub>2</sub> data using the CO<sub>2</sub> system. Second, report the actual O<sub>2</sub> value recorded by the O<sub>2</sub> component, leaving the System ID blank. (The monitor O<sub>2</sub> value will be used in the NO<sub>x</sub> emission rate calculation for the hour, while the substitute data value will be used in the heat input rate calculation.)

- (b) Whenever you use an O<sub>2</sub> monitoring system to determine heat input rate:

Report an MHV record using the O<sub>2</sub> Monitoring System ID, for each hour or partial hour of unit operation. When the hourly O<sub>2</sub> concentration is missing, or for hours in which the flue gases are discharged through an unmonitored bypass stack, use the missing data routines in §75.36 to provide substitute data values.

If the O<sub>2</sub> monitor is also used as the diluent monitor for a NO<sub>x</sub>-diluent monitoring system, whenever O<sub>2</sub> RATA is failed for the O<sub>2</sub> monitoring system, then the NO<sub>x</sub>-diluent monitoring systems is also considered to be out-of-control. (See Appendix B §2.3.2(g).) For heat input that is calculated from the O<sub>2</sub>, report the applicable substitute O<sub>2</sub> concentration data in the MHV record using the applicable missing data procedures for O<sub>2</sub>C. For NO<sub>x</sub> emission rate, report the appropriate substitute data values in the appropriate DHV record. However, if the O<sub>2</sub> data for the O<sub>2</sub> monitoring system is considered out-of-control due to the expiration of the applicable O<sub>2</sub> RATA but the NO<sub>x</sub> RATA has not yet expired,<sup>3</sup> then substitute data should only be used for calculating heat input rate and not for calculation of the NO<sub>x</sub> emission rate. The actual measured O<sub>2</sub> concentration should be used to calculate NO<sub>x</sub> emission rate. In such cases, report an additional O<sub>2</sub> concentration record for each hour until an O<sub>2</sub> RATA is completed. First, report the appropriate substitute O<sub>2</sub> data using the O<sub>2</sub> System ID. Secondly, report the actual O<sub>2</sub> value recorded by the O<sub>2</sub> component leaving the System ID blank. (The recorded O<sub>2</sub> value will be used in the NO<sub>x</sub> emission rate calculation for the hour, while the O<sub>2</sub>C substitute data value will be used in the heat input rate calculations.)

- (c) If the O<sub>2</sub> value is used only for calculating NO<sub>x</sub> emission rate, then report the MHV record for O<sub>2</sub> only when quality-assured values are obtained for both O<sub>2</sub> and NO<sub>x</sub> concentration. Leave the System ID blank. Note that hours in which the flue gases are discharged through an unmonitored bypass stack are considered to be missing data

---

<sup>2</sup> Note that this situation should only arise if the NO<sub>x</sub> emission rate RATA was done using O<sub>2</sub> as the diluent for the reference method or if the CO<sub>2</sub> RATA data are not submitted. If the RATA was conducted using a CO<sub>2</sub> diluent in the reference method, then there should be sufficient CO<sub>2</sub> data available to submit a RATA for the CO<sub>2</sub> system.

<sup>3</sup> Note that this situation should only arise if the NO<sub>x</sub> emission rate RATA was done using CO<sub>2</sub> as the diluent for the reference method or if the O<sub>2</sub> RATA data are not submitted. If the RATA was conducted using an O<sub>2</sub> diluent in the reference method, then there should be sufficient O<sub>2</sub> data available to submit a RATA for the O<sub>2</sub> system.

hours. (For these hours, do not report an MHV record. In the DHV record, report the NO<sub>x</sub> MER and an MODC of "23.")

- (d) If you also use wet and dry O<sub>2</sub> monitors to determine the hourly percent moisture:

Report two O<sub>2</sub> MHV records for each hour. Report the wet O<sub>2</sub> measurement with a "W" as the Moisture Basis data element and report the dry O<sub>2</sub> measurement with a "D" as the Moisture Basis data element. If either the wet or dry O<sub>2</sub> component is also used to calculate heat input, NO<sub>x</sub> emission rate, and/or CO<sub>2</sub> concentration, then follow the applicable reporting instructions from sections (a), (b), or (c), above, to report the data for that component. For the remaining component, report the MHV for each hour, and leave the System ID blank.

If either O<sub>2</sub> value is missing, or for hours in which the flue gases are discharged through an unmonitored bypass stack, perform missing moisture data substitution in the DHV record for moisture, in accordance with §75.37.

### Moisture (H<sub>2</sub>O)

For any unit or stack that monitors H<sub>2</sub>O with a moisture sensor (or, for saturated gas streams, from a temperature sensor and look-up table), report the moisture value in a moisture MHV record for each operating hour or partial operating hour.

**Table 14**  
**MHV Elements for H<sub>2</sub>O**

MHV Elements to Report	H <sub>2</sub> O	
	Measured Data	Missing Data
Parameter Code	✓	✓
Unadjusted Hourly Value	✓	✓
Adjusted Hourly Value		
MODC	✓	✓
Monitoring System ID	✓	
Component ID	✓	
Percent Available	✓	✓
Moisture Basis		

If you use a fuel-specific default moisture value, as allowed under §75.11 or §75.12 (for coal, wood, and natural gas burning units only), report the value in the MONITOR DEFAULT DATA record and use this constant in the calculation. Do not report a moisture MHV record on an hourly basis. However, if you have more than one active fuel-specific default moisture value

defined in your monitoring plan, report the fuel-specific or pro-rated moisture value used in your emissions calculations in an H<sub>2</sub>O DHV record.

The Part 75 missing data procedures for moisture are found in §75.37. These procedures are modeled after the standard missing data procedures for SO<sub>2</sub>. In most instances, the moisture missing data algorithm is the inverse of the SO<sub>2</sub> algorithm (i.e., the lower moisture values are more conservative and therefore an inverted moisture missing data algorithm must be applied (using 10th percentile values instead of 90th percentile values, minimum values instead of maximum values, etc.)). However, when Equations 19-3, 19-4, or 19-8 from Method 19 of 40 CFR Part 60 are used to determine NO<sub>x</sub> emission rate, a higher moisture value is more conservative and therefore the standard SO<sub>2</sub> missing data algorithm must be applied.

## MONITOR HOURLY VALUE DATA XML Elements

### Parameter Code

*Element Name:* ParameterCode

Report the Parameter Code that corresponds to the parameter monitored at the location defined by the Stack Pipe ID or Unit ID. Use the appropriate uppercase code as shown in Table 15.

**Table 15**  
**Parameter Codes and Descriptions for the MHV DATA Record**

Code	Description
CO2C	CO <sub>2</sub> Concentration (% , pct)
FLOW	Volumetric Flow Rate (scfh)
H2O	Moisture (using moisture sensors, or temperature sensors) (% , pct)
NOXC	NO <sub>x</sub> Concentration (ppm)
O2C	O <sub>2</sub> Concentration (% , pct)
SO2C	SO <sub>2</sub> Concentration (ppm)

### Unadjusted Hourly Value

*Element Name:* UnadjustedHourlyValue

Report the unadjusted concentration or stack flow value for the hour. See below for parameter-specific instructions.

#### SO<sub>2</sub> Concentration

Report the unadjusted, quality-assured SO<sub>2</sub> concentration for the hour, expressed in parts per million (ppm) and round the resulting value to the appropriate number of decimal places per Table 16. Leave this field blank for hours in which you use substitute data.

Leave this field blank for hours in which the flue gases are routed through an unmonitored bypass stack, or when the outlet SO<sub>2</sub> monitor is unavailable and proper operation of the emission controls is not verified, if you report the MPC for those hours. However, if you report data from a certified inlet monitor during those hours, report the unadjusted SO<sub>2</sub> concentration recorded by the monitor.

Do not leave this field blank for hours in which: (1) very low sulfur fuel is combusted and you report a 2.0 ppm default value; or (2) you use the default high range value of 200 percent of the MPC in the calculation of the hourly SO<sub>2</sub> concentration; or (3) a full-scale exceedance occurs and you use 200 percent of the range in the calculation of the hourly SO<sub>2</sub> concentration. All of the hours described in (1) – (3), above, are treated as quality-assured monitor operating hours.

### NO<sub>x</sub> Concentration

For both NO<sub>x</sub> concentration monitoring systems and NO<sub>x</sub>-diluent monitoring systems, report the unadjusted, quality-assured NO<sub>x</sub> concentration for the hour, expressed in parts per million (ppm) and round the resulting value to the appropriate number of decimal places per Table 16. Leave this field blank for hours in which you use substitute data for NO<sub>x</sub> concentration.

Do not leave this field blank for hours in which: (1) you use a default high range value of 200 percent of the MPC in the calculation of the hourly NO<sub>x</sub> concentration; or (2) a full-scale exceedance occurs and you use 200 percent of the range in the calculation of the hourly NO<sub>x</sub> concentration. All of the hours described in (1) and (2), above are treated as quality-assured monitor operating hours. Refer to the Part 75 Emissions Monitoring Policy Manual for further discussion of overscaling and use of the default high range.

For units with add-on NO<sub>x</sub> emission controls, if you report data from a certified control device inlet monitor during hours in which the outlet NO<sub>x</sub> monitor is unavailable and proper operation of the emission controls is not verified, report the average, unadjusted NO<sub>x</sub> concentration recorded by the inlet monitor.

### CO<sub>2</sub> Concentration

Report the CO<sub>2</sub> concentration for the hour, expressed in percent CO<sub>2</sub> (%CO<sub>2</sub>) and round the resulting value to the appropriate number of decimal places per Table 16. If applicable, during hours in which you use substitute data, or for hours in which the flue gases are discharged through an unmonitored bypass stack, report the substituted value obtained from the CO<sub>2</sub> missing data procedures under §§75.35 or 75.36 (as applicable). If applicable for NO<sub>x</sub> emission rate calculations, for each hour in which you use the diluent cap value to calculate NO<sub>x</sub> emission rate, report the actual quality-assured CO<sub>2</sub> concentration in MHV record for CO2C and appropriate MODC ("01" through "04"), and report an MODC of "14" in the DHV record for NO<sub>x</sub> emission rate.

Whenever it is necessary to report a second CO<sub>2</sub> concentration record to calculate NO<sub>x</sub> emission rate for an hour, report the actual CO<sub>2</sub> concentration for the hour and the appropriate MODC (either "01" or "02"). See instructions under Description of Data for CO<sub>2</sub> Concentration.

### O<sub>2</sub> Concentration

Report O<sub>2</sub> concentration for the hour, expressed in %O<sub>2</sub>, and round the resulting value to the appropriate number of decimal places per Table 16. For each hour in which you use the diluent cap value to calculate NO<sub>x</sub> emission rate, report the actual quality-assured O<sub>2</sub> concentration and appropriate MODC ("01" through "04"). For each such hour, report an MODC of "14" in the NO<sub>x</sub> emission rate DHV record, to indicate that the diluent cap is being used for NO<sub>x</sub> emission rate.

For any hour in which there is a full scale exceedance of the O<sub>2</sub> monitor range, report the appropriate diluent cap value for the type of unit and an MODC of "20." You must also report a default record in the monitoring plan with a parameter code of O2X and a Default Purpose Code of "DC" containing this value even if you do not calculate an hourly NO<sub>x</sub> Emissions Rate. (Note that you may instead report a time weighted average calculated using the diluent cap value for the portion of the hour that the monitoring range was exceeded with the quality assured data collected during the portion of the hour when the range was not exceeded. In this case, report the hourly average but use an MODC of "20" to indicate a range exceedance has occurred during the hour.)

If you use wet and dry O<sub>2</sub> monitors to determine the hourly percent moisture and both values are quality-assured, report two O<sub>2</sub> MHV records for each hour.

If you use O<sub>2</sub> concentration for the heat input rate calculation, report the appropriate substitute data value in this field when a quality-assured O<sub>2</sub> concentration for the hour is unavailable or for hours in which the flue gases are discharged through an unmonitored bypass stack. Otherwise, if a quality-assured O<sub>2</sub> concentration is not obtained, do not report an MHV record for the hour.

### Moisture

Report moisture for the hour, expressed in %H<sub>2</sub>O, and round the resulting value, obtained either from a moisture sensor, or for saturated gas streams, from a temperature sensor and look-up table, to the appropriate number of decimal places per Table 16. Report the appropriate substitute data value for hours in which a quality-assured moisture percentage is unavailable or for hours in which the flue gases are discharged through an unmonitored bypass stack.

### Volumetric Flow

For each operating hour (or partial operating hour) in which a quality-assured flow rate was measured (MODC "01" through "04" and "54"), report the unadjusted flow rate in units of scfh (wet-basis). Report flow rate to the appropriate number of decimal places per Table 16. For missing data hours, leave this field blank (this includes hours in which the flue gases are discharged through an unmonitored bypass stack).

If a start-up or shut-down hour results in a stack flow rate that is too low to be registered by the stack flow monitor, you may report a default minimum stack flow rate of 1,000 scfh. Report an MODC of "55" for the hour. Manual entry of this MODC is permitted.

**Adjusted Hourly Value**

*Element Name: AdjustedHourlyValue*

Leave this field blank for parameters CO2C, H2O, and O2C.

SO<sub>2</sub> Concentration

For each hour in which you obtain quality-assured values, apply the appropriate bias adjustment factor (BAF) to the rounded average SO<sub>2</sub> concentration for the hour. Report the adjusted SO<sub>2</sub> concentration for the hour in ppm and round the resulting value to the appropriate number of decimal places per Table 16.

Note that for an initial certification, analyzer replacement, or complete monitoring system replacement (as indicated by reporting a QA AND CERTIFICATION EVENT record with a QACertificationEventCode value of "100," "101," "120," or "125"), if you are using conditional data validation, the BAF is uncertain during the conditional data period. Therefore, apply a BAF of 1.000 from the beginning of the conditional data validation period to the completion hour of the certification or recertification RATA.

For each hour in which you use missing data procedures, report the substitute data value.

For each hour in which the flue gases are routed through an unmonitored bypass stack, or when the outlet SO<sub>2</sub> monitor is unavailable and proper operation of the emission controls is not verified, you may either report the MPC in this field or, if data are available from a certified inlet monitor, report the bias-adjusted SO<sub>2</sub> concentration measured by the monitor.

For each hour in which only very low sulfur fuel (as defined in §72.2) is combusted, report the bias-adjusted hourly average SO<sub>2</sub> concentration, unless it is less than 2.0 ppm, in which case, report "2.0 ppm."

For each hour in which a default high range value is used in the calculation of the hourly average SO<sub>2</sub> concentration, report the bias-adjusted hourly average in this field unless application of the BAF causes the hourly average to exceed 200 percent of the MPC, in which case, report 200 percent of the MPC.

When a full-scale exceedance of the high range occurs and 200 percent of the range is used in the calculation of the hourly average SO<sub>2</sub> concentration, report the bias-adjusted hourly average in this field unless application of the BAF causes the hourly average to exceed 200 percent of the range, in which case, report 200 percent of the range.

Refer to the Part 75 Emissions Monitoring Policy Manual for a further discussion of overscaling and use of the default high range value.

NO<sub>x</sub> Concentration

Report data in this field only if you use NO<sub>x</sub> concentration times stack flow rate to determine NO<sub>x</sub> mass emissions. Leave this field blank if you do not have a NO<sub>x</sub> concentration system.

For each hour in which you obtain a quality-assured value, apply the appropriate adjustment factor (1.000 or system BAF) to the rounded average NO<sub>x</sub> concentration for the hour. Report the adjusted average NO<sub>x</sub> concentration for the hour in ppm and round the resulting value to the appropriate number of decimal places per Table 16.

Note that for an initial certification, analyzer replacement, or complete monitoring system replacement (as indicated by reporting a QA AND CERTIFICATION EVENT record with a QACertificationEventCode value of "100," "101," "120," or "125"), if you are using conditional data validation, the BAF is uncertain during the conditional data period. Therefore, apply a BAF of 1.000 from the beginning of the conditional data validation period to the completion hour of the certification or recertification RATA.

For each hour in which NO<sub>x</sub> concentration is missing, report the substitute NO<sub>x</sub> concentration value.

For each hour in which a default high range value is used in the calculation of the hourly average NO<sub>x</sub> concentration, report the bias-adjusted hourly average in this field, unless it exceeds 200 percent of the MPC, in which case, report 200 percent of the MPC.

When a full-scale exceedance of the high range occurs and 200 percent of the range is used in the calculation of the hourly average NO<sub>x</sub> concentration, report the bias-adjusted hourly average in this field, unless it exceeds 200 percent of the range, in which case, report 200 percent of the range.

For units with add-on NO<sub>x</sub> emission controls, if you report data from a certified NO<sub>x</sub> monitor at the control device inlet during hours in which the outlet NO<sub>x</sub> monitor is unavailable and proper operation of the emission controls is not verified, report the average, bias-adjusted NO<sub>x</sub> concentration recorded by the monitor. Include these hours in the missing data lookbacks and treat them as available hours in the PMA calculations.

#### Volumetric Flow

For hours in which quality-assured data are obtained, apply the appropriate bias adjustment factor (1.000 or BAF) to the rounded quality-assured value and report the adjusted stack flow for the hour. Report the resulting value to the appropriate number of decimal places per Table 16. For each hour in which missing data procedures are used to report data, report the substitute data value. When the flue gases are discharged through an unmonitored bypass stack, report the appropriate substitute data value for flow rate (under §75.33) in this field. Do not leave this field blank.

Note that for an initial certification, analyzer replacement, or monitoring system replacement (as indicated by reporting a QA AND CERTIFICATION EVENT record with a QACertificationEventCode value of "300" or "305"), if you are using conditional data validation, the BAF is uncertain during the conditional data period. Therefore, apply a BAF of 1.000 from the beginning of the conditional data validation period to the completion hour of the certification or recertification RATA.

**Table 16**  
**Precision of Reported Values for MONITOR HOURLY VALUE DATA**

Parameter Codes	Number of Decimal Places*
CO2C, H2O, O2C	One
NOXC, SO2C	One
FLOW	Nearest 1,000

\* All substitute data values should be rounded to the same decimal precision as quality-assured data.

### MODC Code

*Element Name: MODCCode*

Report the appropriate method of determination code (MODC) to identify the type of monitoring system or value used to measure and report the concentration or stack flow for the hour. Manual entry of MODCs "16," "17," and "21" is permitted. EPA has reserved codes "01" through "55." Codes "56" through "99" may be used by vendors and companies for other purposes but must not be reported in a quarterly report.

**Table 17**  
**MODC Codes and Descriptions for MHV**

Code	Parameters	Description
01	All	Primary Monitoring System (and Primary Bypass (PB)).
02	All	Redundant Backup or Regular Non-Redundant Backup Monitoring System.
03	All	Approved Alternative Monitoring System.
04	All	Reference Method Backup System.
05	SO2C, NOXC	Preapproved Parametric Monitoring Method Data for Controlled Units.
	FLOW	Part 75 Approved Parametric Method.
06	All	Average Hour Before/Hour After.
07	All	Average Hourly Value, Initial Missing Data.

(cont.)

**Table 17**  
**MODC Codes and Descriptions for MHV (cont.)**

<b>Code</b>	<b>Parameters</b>	<b>Description</b>
08	CO2C, NOXC, SO2C, FLOW	90 <sup>th</sup> Percentile Value in Load Range in Lookback Period.
	H2O	90 <sup>th</sup> <u>or</u> 10 <sup>th</sup> Percentile Value in Load Range in Lookback Period.
	O2	10 <sup>th</sup> Percentile Value in Load Range in Lookback Period.
09	CO2C, NOXC, SO2C, FLOW	95 <sup>th</sup> Percentile Value in Load Range in Lookback Period (for the corresponding load bin, if applicable).
	H2O	95 <sup>th</sup> <u>or</u> 5 <sup>th</sup> Percentile Value in Load Range in Lookback Period.
	O2	5 <sup>th</sup> Percentile Value in Load Range in Lookback Period.
10	All	Maximum (or Minimum for O <sub>2</sub> or H <sub>2</sub> O, if applicable) Hourly Value in Load Range in Lookback Period.
11	NOXC, FLOW	Average Hourly Value in Load Range in Lookback Period.
12	All	Maximum (or Minimum for O <sub>2</sub> or H <sub>2</sub> O, if applicable) Potential Concentration (MPC) or Flow Rate (see Section 2.1 of Appendix A to Part 75).
13	SO2C, NOXC	Maximum Expected Concentration (MEC) (see §75.34(a)(5)).
15	SO2C, NOXC	1.25 times the maximum hourly controlled concentration at the corresponding load or operation bin, in the applicable lookback period (see §75.34(a)(5)).
16	SO2C	SO <sub>2</sub> Concentration Value of 2.0 ppm during hours when very low sulfur fuels are combusted. These hours are included in missing data lookback and are treated as available hours for percent availability calculation.
17	CO2C, NOXC, O2C, SO2C	Like-Kind Replacement Analyzer.
18	NOXC, SO2C	Maximum Potential Concentration (MPC) used to determine the hourly average for the portion of the hour when a high range monitor was unavailable due to an expired linearity or daily calibration error test. (See Policy Question 9.20)
19	NOXC, SO2C	200 percent of MPC; Default High Range Value. These hours <u>are</u> included in missing data lookback and are treated as available hours for percent availability calculations.
20	CO2C, NOXC, O2C, SO2C, FLOW	200 percent of the full-scale range setting (or diluent cap for O <sub>2</sub> ) when there is full-scale exceedance of high range. These hours <u>are</u> included in missing data lookback and are treated as available hours for percent availability calculations.

(cont.)

**Table 17**  
**MODC Codes and Descriptions for MHV (cont.)**

Code	Parameters	Description
21	CO2C, H2O, NOXC, SO2C	Negative Hourly Average Concentration Replaced with Zero.
22	NOXC, SO2C	Concentration from a certified monitor at the control device inlet, when exhaust gases are routed through an unmonitored bypass stack, or when the outlet monitor is unavailable and proper operation of the emission controls is not verified. These hours are included in missing data lookback and are treated as available hours for percent availability calculations.
23	NOXC, SO2C	MPC when flue gases are routed through an unmonitored bypass stack. These hours are considered to be missing data hours.
24	NOXC	MEC of NO <sub>x</sub> when flue gases are routed through an unmonitored bypass stack and the add-on NO <sub>x</sub> emission controls are confirmed to be operating properly.
53	All	Other quality-assured methodologies approved through petition. These hours are included in the missing data lookback and are treated as available hours for percent monitor availability calculations.
54	All	Other quality-assured methodologies approved through petition by EPA. These hours are included in missing data lookback and are treated as unavailable hours for percent availability calculations.
55	All	Other substitute data approved through petition by EPA. These hours are <u>not</u> included in missing data lookback and are treated as unavailable hours for percent availability calculations.

### SO<sub>2</sub> Concentration

When very low sulfur fuel is combusted, if a negative SO<sub>2</sub> concentration is replaced (in the Unadjusted Hourly Value field) with a value of zero ppm and the 2.0 ppm default SO<sub>2</sub> concentration is reported in the Adjusted Hourly Value field, report MODC "16," rather than "21" for that hour.

### NO<sub>x</sub> Concentration

Note that MODCs "06" through "12," "23," "24," and "55" apply only when a separately certified NOXC monitoring system is defined in the monitoring plan and is used to calculate NO<sub>x</sub> mass and do not apply when only a NO<sub>x</sub>-diluent monitoring system is defined.

### CO<sub>2</sub> Concentration

MODCs "06" through "12" apply only when a CO<sub>2</sub> monitor is used for heat input rate or CO<sub>2</sub>-mass determinations.

### O<sub>2</sub> Concentration

MODCs "06" through "12" apply only when a separately certified O<sub>2</sub> monitoring system is defined in the monitoring plan and is used exclusively for heat input rate determinations in accordance with Equation F-17 or F-18 in Appendix F to Part 75.

#### **Monitoring System ID**

***Element Name:*** *MonitoringSystemID*

For missing data substitution hours, leave this element blank. Note that hours in which the flue gases are discharged through an unmonitored bypass stack are considered to be missing data hours.

For quality-assured data hours, report the ID of the monitoring system from which the concentration or stack flow was recorded, as follows:

### SO<sub>2</sub> Concentration

For quality-assured data hours, report the ID of the Monitoring System from which the concentration value was recorded. Also, report the SO<sub>2</sub> concentration Monitoring System ID for the monitoring system in use at the time of any of the following occurrences: (1) when you report the 2.0 ppm default value for an hour during which very low sulfur fuel (as defined in §72.2) is combusted and the bias-adjusted hourly average SO<sub>2</sub> concentration is below 2.0 ppm; or (2) when you use a default high range value of 200 percent of the MPC in the calculation of the hourly average SO<sub>2</sub> concentration; or (3) when a full-scale exceedance of the high range occurs and you use a value of 200 percent of the range in the calculation of the hourly average SO<sub>2</sub> concentration. In these cases, the hours are treated as quality-assured monitor operating hours. Each of these occurrences is included in missing data lookback and is counted as an available hour for percent monitor data availability calculations.

If a like-kind replacement non-redundant backup analyzer is used during a period of maintenance or repair of the primary analyzer (see §75.20(d)), report the primary Monitoring System ID.

### Volumetric Flow

If a full-scale exceedance occurs and you use a value of 200 percent of the range in the calculation of the hourly average flow rate, report the Monitoring System ID of the monitoring system which is in use at the time of the occurrence. Treat such hours as though they are quality-assured monitor operating hours; include them in missing data lookback and count them as available hours for percent monitor data availability calculations.

### NO<sub>x</sub> Concentration

If the NO<sub>x</sub> analyzer is only part of a NO<sub>x</sub> emission rate system and not part of any NO<sub>x</sub> concentration system, leave this field blank.

Otherwise, report the System ID for the NO<sub>x</sub> concentration system.

When reporting a default high range value of 200 percent of the MPC or when reporting a value of 200 percent of the range during a full-scale exceedance of the high range, report the System ID of the monitoring system in use at the time of the occurrence of the full-scale exceedance.

If a like-kind replacement non-redundant backup analyzer is used during a period of maintenance or repair of the primary analyzer (see §75.20(d)), report the primary Monitoring System ID.

#### CO<sub>2</sub> Concentration

If the CO<sub>2</sub> analyzer is only part of a NO<sub>x</sub> emission rate system, leave the System ID blank.

Otherwise, report the applicable System ID for the CO<sub>2</sub> monitoring system defined in the monitoring plan.

Report the Monitoring System ID of the monitoring system in use whenever a full-scale exceedance value of 200 percent of the range is used in the calculation of the hourly average CO<sub>2</sub> concentration. Treat such hours as though they are quality-assured monitor operating hours; include them in missing data lookback and count them as available hours for percent monitor data availability calculations.

If a like-kind replacement non-redundant backup analyzer is used during periods of maintenance and repair of the primary analyzer (see §75.20(d)), report the primary Monitoring System ID.

#### O<sub>2</sub> Concentration

If the O<sub>2</sub> analyzer is only part of a NO<sub>x</sub> emission rate system (and/or an H<sub>2</sub>O system), leave the System ID blank and use only component IDs to identify the origin of the O<sub>2</sub> concentration values. Otherwise, report the applicable System ID as follows:

- (a) If the O<sub>2</sub> concentration is from an O<sub>2</sub> component of an O<sub>2</sub> monitoring system (used to determine hourly heat input rate), report the System ID for the O<sub>2</sub> monitoring system. (Note: the data will be QA'd by an O<sub>2</sub> RATA.)
- (b) If the O<sub>2</sub> concentration is from an O<sub>2</sub> component that is part of a CO<sub>2</sub> monitoring system (used for determining CO<sub>2</sub> concentration, CO<sub>2</sub> mass, and hourly heat input rate), report the System ID for the CO<sub>2</sub> monitoring system. (Note: the data will be QA'd by a CO<sub>2</sub> RATA.)

(Note that when either the wet or the dry O<sub>2</sub> component is part of either an O<sub>2</sub> or CO<sub>2</sub> monitoring system, that component will be reported using the applicable monitoring system as described in (a) and (b) above.)

#### H<sub>2</sub>O Concentration

Report the H<sub>2</sub>O System ID for every quality-assured hour.

**Component ID**

*Element Name: ComponentID*

For each hour of quality-assured data from a CEM or stack flow system, identify the component used during the hour. Note that hours in which the flue gases are discharged through an unmonitored bypass stack are considered to be missing data hours.

If a like-kind replacement non-redundant backup analyzer is used during periods of maintenance and repair of the primary analyzer (see §75.20(d)), assign and report a unique Component ID number (beginning with the prefix "LK" as defined in the COMPONENT DATA record, e.g., "LK1") for the like-kind replacement analyzer. The like-kind replacement analyzer Component ID may be manually entered. Note that the LK component must also be identified in the monitoring plan as a monitoring component for each monitoring system that will use the data.

**Volumetric Flow**

If you determine hourly stack flow rate by averaging (or subtracting) the readings from two flow components which are identified as components of the same monitoring system, leave this field blank. If the hourly flow rate is a substitute data value, leave this field blank. This includes hours in which the flue gases are discharged through an unmonitored bypass stack.

**Percent Available**

*Element Name: PercentAvailable*

If applicable for the parameter, report the percent monitor data availability to one decimal place for each hour.

**SO<sub>2</sub> Concentration**

For units with add-on SO<sub>2</sub> emission controls:

- (a) If you report the MPC for hours in which the flue gases are routed through an unmonitored bypass stack, or when the outlet SO<sub>2</sub> monitor is unavailable and proper operation of the emission controls is not verified, do not include these hours in the calculation of percent monitor data availability. Treat these hours as missing data hours.
- (b) If you report data from a certified inlet monitor during hours in which the flue gases are routed through an unmonitored bypass stack, or when the outlet SO<sub>2</sub> monitor is unavailable and proper operation of the emission controls is not verified, include these hours in the missing data lookbacks and treat them as available hours in the PMA calculations.

**NO<sub>x</sub> Concentration**

Report data in this field only if you use NO<sub>x</sub> concentration times stack flow as the primary methodology for NO<sub>x</sub> mass calculations for all hours. Report the percent monitor data availability for each hour.

CO<sub>2</sub> Concentration

Report percent monitor data availability for CO<sub>2</sub> concentration only when the CO<sub>2</sub> value is used for determining CO<sub>2</sub> mass rate or heat input rate.

O<sub>2</sub> Concentration

Report percent monitor data availability for O<sub>2</sub> concentration only when the O<sub>2</sub> value is used for determining heat input rate.

Moisture (H<sub>2</sub>O)

If you use the standard moisture missing data procedures in §75.37, which are based on percent availability, calculate and report the moisture percent data availability for each operating hour.

**Moisture Basis**

*Element Name: MoistureBasis*

If you use wet and dry O<sub>2</sub> values to determine hourly moisture, report one of the following uppercase codes to indicate the moisture basis of the O<sub>2</sub> reading.

**Table 18**  
**Moisture Basis Codes and Descriptions**

Code	Description
D	Dry
W	Wet

## 2.4.2 DERIVED HOURLY VALUE DATA

### DERIVED HOURLY VALUE DATA XML Model

**Figure 10**  
**DERIVED HOURLY VALUE DATA XML Elements**

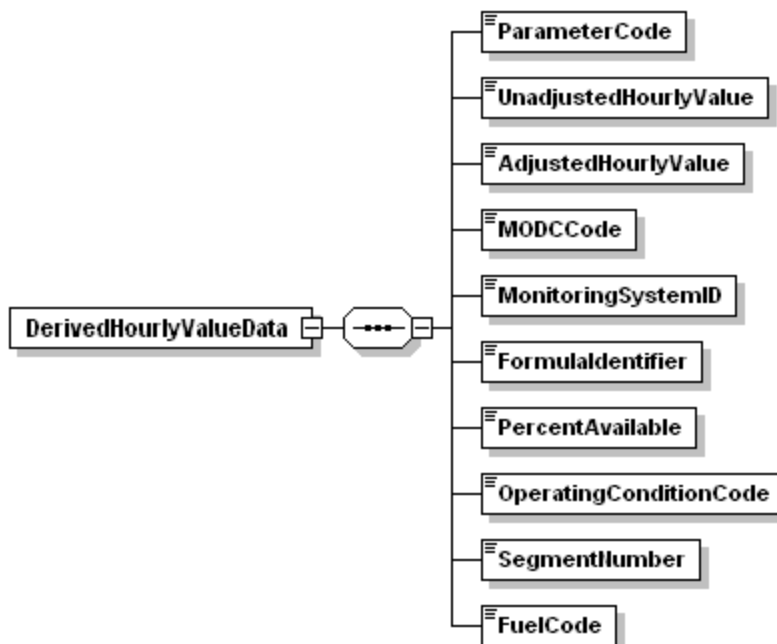

### DERIVED HOURLY VALUE DATA Overview

#### Description of Data

Submit a DERIVED HOURLY VALUE DATA (DHV) record for each overall parameter value determined at this monitoring location for each operating hour (or partial hour). This includes emissions values calculated from continuous emissions monitoring (CEM) data, as well as the overall NO<sub>x</sub> emission rate determined using Appendix E, the overall mass emission rates and heat input rate determined using Appendix D and Appendix G, and the hourly value for each parameter determined using the low mass emissions (LME) provisions. For hours in which the unit or stack did not operate, do not report this record. Derived emissions values include SO<sub>2</sub> mass or mass rate, NO<sub>x</sub> emission rate, NO<sub>x</sub> mass or mass rate, calculated H<sub>2</sub>O concentration, calculated CO<sub>2</sub> concentration, Heat Input or Heat Input rate, and CO<sub>2</sub> mass or mass rate values. Reporting stipulations for each of the derived parameters are described in more detail below.

### For CEM Methods

#### Derived Hourly Heat Input Rate (mmBtu/hr)

For each unit or stack with a stack flow monitor and diluent monitor, report the calculated heat input rate in the AdjustedHourlyValue element of a DHV record. If you monitor heat input rate and report this record at a common stack, also apportion the heat input rate measured at the common stack to the individual units (i.e., report additional DHV records for heat input rate under the associated Unit IDs). If you monitor heat input rate and report this record at multiple stacks, also report the heat input rate for the unit in an additional DHV record.

#### Derived SO<sub>2</sub> Hourly Mass Emission Rate (lb/hr)

For each unit or stack with an SO<sub>2</sub> CEMS (or using the F23 methodology per §75.11(e)(1)), report the calculated SO<sub>2</sub> mass emission rate in the AdjustedHourlyValue element of a DHV record.

If you monitor SO<sub>2</sub> mass emission rate and report this record at a common stack, do not apportion the SO<sub>2</sub> mass emission rate measured at the common stack to the individual units (i.e., do not report any additional DHV records under the associated Unit IDs).

If, for a particular unit, you monitor SO<sub>2</sub> mass emission rate at multiple stacks (or ducts), do not report the combined SO<sub>2</sub> mass emission rate for the unit (i.e., do not report any unit-level DHV records).

#### Derived NO<sub>x</sub> Hourly Emission Rate (lb/mmBtu)

For each unit or stack with a NO<sub>x</sub> emission rate CEMS, report the calculated NO<sub>x</sub> emission rate in the UnadjustedHourlyValue element and the bias-adjusted emission rate in the AdjustedHourlyValue element of a DHV record. If you monitor NO<sub>x</sub> emission rate and report this record at a common stack, do not apportion the NO<sub>x</sub> emission rate measured at the common stack to the individual units (i.e., do not report any additional DHV records under the associated Unit IDs).

If, for a particular unit, you monitor NO<sub>x</sub> emission rate at multiple stacks (or ducts), calculate the heat-input weighted hourly emission rate for the unit, but do not report those hourly unit level values (i.e., do not report any unit-level DHV records for NO<sub>x</sub> emission rate). Rather, only use them to calculate the quarterly and cumulative NO<sub>x</sub> emission rates for the unit. Report these quarterly and cumulative values in the unit-level SUMMARY VALUE DATA record.

For a combined-cycle turbine that uses a multiple-stack configuration, report separate stack-level DHV records for each hour in which there is both main stack and bypass stack operating time. Then, calculate a time-weighted unit-level NO<sub>x</sub> emission rate for each hour, as described in the SUMMARY VALUE DATA record instructions. Store, but do not report, these time-weighted, hourly unit-level emission rates. Rather, only use them to calculate the quarterly and cumulative unit-level NO<sub>x</sub> emission rates.

### For Derived NO<sub>x</sub> Mass Emission Rate (lb/hr)

For each unit, stack, or pipe at which NO<sub>x</sub> mass emissions are measured or estimated, submit a DHV record, for every hour in the reporting period that the unit or stack operates.

If you monitor NO<sub>x</sub> mass emissions and report this record at a common stack, do not apportion the NO<sub>x</sub> mass emissions measured at the common stack to the individual units (i.e., do not report any additional DHV records under the associated Unit IDs).

If, for a particular unit, NO<sub>x</sub> mass emissions is monitored at multiple stacks (or ducts), do not report the combined hourly NO<sub>x</sub> mass emissions for the unit (i.e., do not report any unit-level DHV records for NO<sub>x</sub> mass rate).

### Derived CO<sub>2</sub> Mass Emission Rate (tons/hr)

For any operating hour (or partial hour) for each unit, stack, or pipe at which CO<sub>2</sub> emissions are monitored using CEMS, including the use of O<sub>2</sub> CEMS, report CO<sub>2</sub> mass emission rate in a DHV record.

If you monitor CO<sub>2</sub> mass emission rate and report this record at a common stack, do not apportion the CO<sub>2</sub> mass emission rate measured at the common stack to the individual units (i.e., do not report any additional DHV records under the associated unit IDs).

If, for a particular unit, CO<sub>2</sub> mass emission rate is monitored at multiple stacks (or ducts), do not report the combined CO<sub>2</sub> mass emission rate for the unit (i.e., do not report any unit-level DHV records).

### Derived CO<sub>2</sub> Concentration

For any operating hour (or partial hour) for each unit or stack at which CO<sub>2</sub> concentration is determined by calculating it from O<sub>2</sub> readings, report the derived CO<sub>2</sub> concentration value for each operating hour or partial operating hour in this record. Note that measured CO<sub>2</sub> concentration from a CO<sub>2</sub> system utilizing a CO<sub>2</sub> monitor should be recorded in the MONITOR HOURLY VALUE DATA (MHV) record.

### Derived H<sub>2</sub>O (Moisture) Value

For any operating hour (or partial hour) for each unit or stack at which moisture is determined by calculating it from wet and dry O<sub>2</sub> readings, report the derived moisture value for each operating hour or partial operating hour in this record.

- Note that measured H<sub>2</sub>O values from a moisture sensor or a temperature sensor and look-up table, if reporting for saturated gas streams, should be reported in the MHV record.

If you use a fuel-specific default moisture value, as allowed under §75.11 or §75.12 (for coal and wood-burning units and natural gas-fired boilers) and you have just one default value defined in your monitoring plan, do not report a MHV record or a DHV record on an hourly basis.

However, if you have more than one active fuel-specific default moisture value defined in your monitoring plan, report the fuel-specific or pro-rated moisture value used in your emissions calculations in an H<sub>2</sub>O DERIVED HOURLY VALUE DATA record with a Method of Determination Code (MODC) of "40" on an hourly basis.

#### Derived SO<sub>2</sub> Hourly Emission Rate (lb/mmBtu)

If you are using the F23 methodology to calculate the SO<sub>2</sub> mass rate per §75.11(e)(1) and you have defined more than one fuel-specific SO<sub>2</sub> emission rate default value in your monitoring plan, report the fuel-specific or pro-rated default value used in your emissions calculations in an SO<sub>2</sub>R DERIVED HOURLY VALUE DATA record with an MODC of "40" on an hourly basis.

### Appendix D Methods

#### Heat Input

If you use Appendix D fuel flowmetering to determine heat input, report the heat input rate calculated for each fuel in the appropriate HOURLY PARAMETER FUEL FLOW DATA records. In addition, report the total heat input rate for the hour in a DHV record for the location. (You must report this record even if only one fuel was combusted during the hour.) If the fuel flowmetering is at a common pipe, also report the apportioned hourly heat input rate in a DHV record for each unit that is part of the common pipe.

#### SO<sub>2</sub>

If you use Appendix D fuel flowmetering to determine SO<sub>2</sub>, report the SO<sub>2</sub> mass emission rate calculated for each fuel in the appropriate HOURLY PARAMETER FUEL FLOW DATA record. In addition, report the total SO<sub>2</sub> mass emission rate for the hour in a DHV record for the location. (You must report this record even if only one fuel was combusted during the hour.) If the fuel flowmetering is at a common pipe, do not report hourly apportioned SO<sub>2</sub> for the units.

### Appendix G Method for Hourly CO<sub>2</sub>

If you use Equation G-4 to determine hourly CO<sub>2</sub>, report the CO<sub>2</sub> mass emission rate calculated for each fuel in the appropriate HOURLY PARAMETER FUEL FLOW DATA record. In addition, report the total CO<sub>2</sub> mass emission rate for the hour in a DHV record. (You must report this record even if only one fuel was combusted during the hour.)

### Appendix E Method for Hourly NO<sub>x</sub> Emission Rate

If you use Appendix E to determine NO<sub>x</sub> emission rate, report the overall NO<sub>x</sub> emission rate for the hour in a DHV record. If you burn a single, consistent blend of fuels and established a single Appendix E curve for that fuel blend, report all the Appendix E related information in this DHV record. If you established a separate Appendix E curve for each fuel, report the fuel-specific NO<sub>x</sub> emission rate data in the appropriate HOURLY PARAMETER FUEL FLOW DATA record and in addition, report the overall NO<sub>x</sub> emission rate for the hour in a DHV record. (You must report this record even if only one fuel was combusted during the hour.)

Hourly NO<sub>x</sub> Mass Rate Based on Appendix D Heat Input Rate

If you are required to report NO<sub>x</sub> mass rate, calculate this value from the heat input rate and NO<sub>x</sub> emission rate reported in the DHV record and report it in a DHV record.

LME Methods

For each parameter reported using the LME method, report a DHV record for each operating hour.

**DERIVED HOURLY VALUE DATA XML Elements****Parameter Code**

*Element Name:* ParameterCode

Report the appropriate Parameter Code as shown in Table 19.

**Table 19**  
**Parameter Codes and Descriptions for the DHV DATA Record**

Code	Description
CO2	CO <sub>2</sub> Hourly Mass Emission Rate (tons/hr)
CO2C	CO <sub>2</sub> Concentration (derived from O <sub>2</sub> measurements) (%CO <sub>2</sub> )
CO2M	CO <sub>2</sub> Hourly Mass (tons) (LME)
H2O	Moisture (from wet/dry O <sub>2</sub> measurements) (%H <sub>2</sub> O)
HI	Heat Input Rate (mmBtu/hr)
HIT	Heat Input Total (mmBtu) (LME)
NOX	NO <sub>x</sub> Hourly Mass Emission Rate (lb/hr)
NOXM	NO <sub>x</sub> Hourly Mass (lb) (LME)
NOXR	NO <sub>x</sub> Emissions Rate (lb/mmBtu)
SO2	SO <sub>2</sub> Hourly Mass Rate (lb/hr)
SO2M	SO <sub>2</sub> Hourly Mass (lb) (LME)
SO2R	SO <sub>2</sub> Hourly Emission Rate (lb/mmBtu)

**Unadjusted Hourly Value**

*Element Name:* *UnadjustedHourlyValue*

Report the unadjusted derived hourly value for the parameter specified, as follows:

**NO<sub>x</sub> Emission Rate from CEM**

Calculate and report the NO<sub>x</sub> emission rate (lb/mmBtu) based on the unadjusted NO<sub>x</sub> concentration and unadjusted diluent (CO<sub>2</sub> or O<sub>2</sub>) concentration recorded in the MHV record. Report the resulting value to the appropriate number of decimal places in Table 20. For hours in which you use missing data procedures leave this field blank, including hours in which the flue gases are discharged through an unmonitored bypass stack.

If you use Equation 19-3 or 19-5 to determine NO<sub>x</sub> emission rate, you must use modified Equation 19-3D or 19-5D (as applicable) instead of Equation 19-3 or 19-5, for hours in which you use the diluent cap (see Table 29 in the MONITORING FORMULA DATA record in the Monitoring Plan Reporting Instructions).

For all other parameters, leave this field blank.

**Adjusted Hourly Value**

*Element Name:* *AdjustedHourlyValue*

Report the adjusted or "final" derived hourly value for the parameter specified.

**SO<sub>2</sub> Mass Emission Rate (lb/hr)**

For CEM methods, this value is normally derived using the bias-adjusted stack flow and the bias-adjusted SO<sub>2</sub> concentration (each reported in the MHV record), in conjunction with the appropriate equation in Appendix F to Part 75. However, for an hour in which a very low sulfur fuel (see §72.2) is combusted, the value may be calculated from a CEMS-derived heat input rate (i.e., from monitored stack flow rate, and diluent (CO<sub>2</sub> or O<sub>2</sub>) concentration) and a default SO<sub>2</sub> emission rate using Equation F-23 (see §75.11(e)(1)).

For Appendix D units and pipes, report the total SO<sub>2</sub> mass emission rate for the location in this field. Use formula D-12 to combine SO<sub>2</sub> mass emission rates from multiple fuels (as reported in HOURLY PARAMETER FUEL FLOW).

Report all data for this element in lb/hr and to the appropriate number of decimal places per Table 20.

**NO<sub>x</sub> Mass Emission Rate (lb/hr)**

If you use NO<sub>x</sub> concentration times stack flow rate to determine NO<sub>x</sub> mass emissions, use the bias-adjusted stack flow and the bias-adjusted NO<sub>x</sub> concentration, (each reported in the MHV record), in conjunction with the appropriate equation in Appendix F to Part 75. If instead, NO<sub>x</sub> mass emissions are calculated from the NO<sub>x</sub> emission rate times heat input rate, use the adjusted NO<sub>x</sub> emission rate and adjusted heat input values as reported in the DHV record for each

parameter. Report data for this element in lb/hr and to the appropriate number of decimal places per Table 20.

#### NO<sub>x</sub> Emission Rate (lb/mmBtu)

**CEM Systems.** For each hour in which you report NO<sub>x</sub> emission rate in the Unadjusted Hourly Value element, apply the appropriate adjustment factor (1.000 or bias adjustment factor (BAF)) to the rounded average NO<sub>x</sub> emission rate and report the adjusted NO<sub>x</sub> emission rate for the hour. Report the resulting value to the appropriate number of decimal places per Table 20. Report the appropriate substitute data value for NO<sub>x</sub> emission rate for each hour that a quality-assured emission rate is not obtained, including hours in which the flue gases are discharged through an unmonitored bypass stack. Do not leave this field blank.

Note that for an initial certification, analyzer replacement, or complete monitoring system replacement (as indicated by reporting a QA CERTIFICATION EVENT record with an Event Code of 100, 101, 120, 125, 151, 250, 255, 300 or 305), if you are using conditional data validation, the BAF is uncertain during the conditional data period. Therefore, apply a BAF of 1.000 from the beginning of the conditional data validation period to the completion hour of the certification or recertification RATA. For any other events that require a RATA, apply the BAF from their previous RATA during the conditional data period, unless that RATA failed or was aborted, in which case use 1.000.

For a combined-cycle combustion turbine (CT) using a multiple-stack configuration to report NO<sub>x</sub> emission rate, use missing data substitution for any transition hour (i.e., an hour during which gases flow through both stacks), if either the main stack or bypass monitoring system is out of service, and draw the appropriate substitute data value from the bypass stack data pool.

If a full-scale exceedance of the low NO<sub>x</sub> range occurs and you use a default high range value of 200 percent of the MPC in the calculation of the hourly average NO<sub>x</sub> concentration reported in the MHV record, or if a full-scale exceedance of the high NO<sub>x</sub> range occurs and you use a value of 200 percent of the range in the calculation of the hourly average NO<sub>x</sub> concentration reported in the MHV record, use the reported NO<sub>x</sub> concentration in conjunction with the quality-assured diluent concentration for the hour to calculate and report the NO<sub>x</sub> emission rate. These hours are treated as quality-assured monitor operating hours; they are included in missing data lookback and are treated as available hours for percent monitor data availability calculations.

If a diluent concentration is unavailable during an hour in which a full scale exceedance of the NO<sub>x</sub> analyzer occurs or an hour in which the default high range value is used, the NO<sub>x</sub> emission rate for the hour is considered to be missing. In that case, do not report Monitor Hourly Value for NO<sub>x</sub> concentration for this hour since the NO<sub>x</sub> emission rate cannot be calculated; instead, report the maximum potential NO<sub>x</sub> emission rate (MER) in this field, and use an MODC of "25."

**Appendix E Systems.** Report the overall NO<sub>x</sub> emission rate for the unit to the appropriate number of decimal places per Table 20. If this value was determined from a consistent fuel mix curve, also report the appropriate System ID for the Appendix E NO<sub>x</sub> system. If a single fuel curve or curves were defined, report the fuel-specific NO<sub>x</sub> emission rate in the appropriate PARAMETER FUEL FLOW DATA record(s), and report the combined NO<sub>x</sub> emission rate for the unit in this record.

CO<sub>2</sub> Concentration (Derived from O<sub>2</sub> Concentration) (pct)

Report the CO<sub>2</sub> Concentration for the hour to the appropriate number of decimal places per Table 20. This is either the value calculated from a quality-assured O<sub>2</sub> concentration value (as reported in the MHV record), or the appropriate substitute data value, as specified in §75.35.

CO<sub>2</sub> Mass Emission Rate (tons/hr)

If you are using CEMS, this value is derived using the bias-adjusted stack flow and either the unadjusted CO<sub>2</sub> concentration reported in the MHV record (if you are using a CO<sub>2</sub> analyzer), or the CO<sub>2</sub> Concentration reported in the DHV record (if you are using an O<sub>2</sub> analyzer), in conjunction with the appropriate equation in Appendix F to Part 75.

For units using Appendix G, calculate and report, in PARAMETER FUEL FLOW DATA record(s), the CO<sub>2</sub> mass emissions (tons/hr) for each fuel separately using Equation G-4. Then use Equation G-4A (see Table 32, MONITORING FORMULA DATA record in the Monitoring Plan Reporting Instructions) to determine the combined CO<sub>2</sub> mass emission rate for the hour. Report the combined hourly CO<sub>2</sub> mass emission rate (tons/hr) in this field in the DHV record.

Report this element in tons per hour and to the appropriate number of decimal places per Table 20.

H<sub>2</sub>O (Moisture) (pct)

Report moisture for the hour, expressed in %H<sub>2</sub>O, rounded to one decimal place. Report the appropriate substitute data value for hours in which a quality-assured moisture percentage is unavailable or for hours in which the flue gases are discharged through an unmonitored bypass stack.

Heat Input (HI) Rate (mmBtu/hr)

Report this value in mmBtu per hour (mmBtu/hr) and to the appropriate number of decimal places per Table 20. If you use CEMS to determine hourly heat input rate, calculate the hourly rate using the diluent gas concentration, bias-adjusted hourly stack flow rate, percent moisture (if appropriate), and F-factor.

If you measure and report heat input rate at a common stack or pipe, also apportion and report heat input rate at the unit level. This apportionment should be based on megawatts, steam load, or fuel flow rate, using Equation F-21A, F-21B, or F-21D in Appendix F to Part 75, as applicable. These formulas use time-weighted hourly load to apportion the heat input rate measured at a common stack to the individual units.

For each hour, the sum of the individual heat inputs in mmBtu (i.e., the sum of the individual unit heat input rates, each multiplied by the corresponding unit operating time) must equal the total common stack heat input in mmBtu (i.e., the common stack heat input rate multiplied by the common stack operating time).

For a unit with a multiple stack configuration, with flow rate and diluent monitors on each stack, calculate the hourly heat input rate for the unit using Equation F-21C in Appendix F to Part 75. Also use Equation F-21C for multiple pipe configurations.

For each hour, the total unit heat input in mmBtu (i.e., the unit heat input rate multiplied by the unit operating time) must equal the sum of the individual stack (or pipe) heat inputs in mmBtu (i.e., the sum of the individual stack (or pipe) heat input rates, each multiplied by the corresponding stack (or pipe) operating time).

For Appendix D units combusting multiple fuels, report the hourly heat input rate calculated from all fuels in the DHV record. Report this record even if only one fuel was combusted during the hour.

For non-Acid Rain NO<sub>x</sub> Budget Program units that use NO<sub>x</sub> concentration times stack flow as the primary methodology to calculate NO<sub>x</sub> mass emissions, report the hourly heat input rate unless you are specifically exempted (e.g., by a State SIP) from reporting it for allocation purposes. However, you must report unit operating time and load (except for non load-based units) for each hour in the HOURLY OPERATING DATA record, even if you are not required to report hourly heat input.

If, for any operating hour, the heat input rate is calculated to be less than one mmBtu/hr, substitute for that hour a value of one mmBtu/hr. Use an MODC of "26" for any such hours. This applies only to monitoring locations where CEMS are installed (i.e., where HI Rate is calculated using equation F-15, F-16, F-17, or F-18.) This does not apply to HI Rate calculated through Appendix D or apportionment.

In the rare event no units attached to the common stack generated load (Load = 0) during the hour, heat input should be apportioned by operating time.

#### Total Heat Input (HIT) (mmBtu)

Report this value in mmBtu for LME units and to the appropriate number of decimal places per Table 20.

#### SO<sub>2</sub> Emission Rate (lb/mmBtu)

If you are using the F23 methodology to calculate the SO<sub>2</sub> mass rate per §75.11(e)(1) and you have defined more than one fuel-specific SO<sub>2</sub> emission rate default value in your monitoring plan, report the fuel-specific or pro-rated default value in lb/mmBtu. Report the value to the appropriate number of decimal places per Table 20.

#### LME Units

Report the value for each required parameter as total mass (or heat input) for the hour. Report each value to the appropriate number of decimal places per Table 20.

**Table 20**  
**Precision of Reported Values for DERIVED HOURLY VALUE DATA**

Parameter Codes		Number of Decimal Places
CO2, CO2C, CO2M, H2O, HI, HIT, NOX, NOXM, SO2M		One
SO2	For CEM and Appendix D burning only oil during hour	One
SO2	Appendix D burning any gas during hour	Four
NOXR		Three
SO2R		Four

### MODC Code

*Element Name: MODCCode*

For CEM methods for parameters CO2C, NOXR or H2O, report one of the following MODCs as shown in Table 21 to identify the monitoring system or missing data procedure used to report the derived value or when you were directed to report it for an approved alternative monitoring system. For parameter HI, use an MODC of "26" when the calculated Heat Input Rate is zero or negative and was therefore replaced with a value of 1.0. Report an MODC of "40" for parameters SO2R and H2O when a fuel-specific or pro-rated default value is used in determining the derived value.

For all other parameters, leave this field blank.

### NO<sub>x</sub> Hourly Emission Rate

Report an MODC of "14" when the diluent cap value for CO<sub>2</sub> or O<sub>2</sub> is used in place of the measured value reported in the MHV records. Also, be sure that you register the appropriate diluent cap value for the unit in the MONITORING DEFAULT DATA record in the monitoring plan. A diluent cap value can only be used for calculating NO<sub>x</sub> emission rate during operating hours for which a quality-assured measured diluent (CO<sub>2</sub> or O<sub>2</sub>) value is obtained.

For full-scale exceedances of a NO<sub>x</sub> analyzer, EPA requires reporting of an MODC reflecting the monitoring system in use during the exceedance, or reporting an MODC of "25" if the diluent concentration normally reported in the MHV records is not quality-assured. Therefore, during full-scale exceedances, when 200 percent of MPC or 200 percent of range is reported for NO<sub>x</sub> concentration in the MHV record and is used in conjunction with a quality-assured diluent gas concentration to calculate the NO<sub>x</sub> emission rate, report the MODC code associated with the monitoring system that is in use at the time of the full-scale exceedance (for example, report "01" if the primary NO<sub>x</sub>-diluent monitoring system is in use). If a full-scale exceedance of the NO<sub>x</sub> analyzer occurs and no quality-assured diluent gas concentration for the hour is available, report an MODC of "25" for that hour. Manual entry of an MODC of "21" is permitted.

**Table 21**  
**MODC Codes and Descriptions for DHV**

<b>Code</b>	<b>Parameter(s)</b>	<b>Description</b>
01	CO2C, NOXR, H2O	Primary Monitoring System (and Primary Bypass (PB) for NOXR).
02	CO2C, NOXR, H2O	Redundant Backup or Regular Non-Redundant Backup Monitoring System.
03	All	Approved Part 75 Alternative Monitoring System.
04	CO2C, NOXR, H2O	Reference Method Backup System.
05	NOXR	Part 75 Approved Parametric Method for Controlled Units.
06	CO2C, NOXR, H2O	Average Hour Before/Hour After.
07	CO2C, NOXR, H2O	Average Hourly Value, Initial Missing Data.
08	CO2C, NOXR	90 <sup>th</sup> Percentile Value in Load Range in Lookback Period.
	H2O	90 <sup>th</sup> <u>or</u> 10 <sup>th</sup> Percentile Value in Load Range in Lookback Period.
09	CO2C, NOXR	95 <sup>th</sup> Percentile Value in Load Range in Lookback Period.
	H2O	95 <sup>th</sup> <u>or</u> 5 <sup>th</sup> Percentile Value in Load Range in Lookback Period.
10	CO2C, NOXR	Maximum Hourly Value in Load Range in Lookback Period.
	H2O	Maximum or Minimum Hourly Moisture Percentage in Lookback Period.
11	NOXR	Average Hourly Rate in Load Range in Lookback Period.
12	CO2C, NOXR	Maximum Concentration or Emission Rate.
	H2O	Maximum or Minimum Potential moisture percentage.
13	NOXR	Maximum Controlled NO <sub>x</sub> Emission Rate (MCR).
14	NOXR	Diluent Cap (if the cap is replacing a CO <sub>2</sub> measurement, it should be 5.0 percent for boilers and 1.0 percent for turbines; if it is replacing an O <sub>2</sub> measurement, it should be 14.0 percent for boilers and 19.0 percent for turbines.)
15	NOXR	1.25 times the NO <sub>x</sub> Emission Rate at the corresponding load or operational bin, in the applicable lookback.
21	CO2C, H2O NOXR	A negative hourly value replaced with a zero.
22	NOXR	NO <sub>x</sub> Emission Rate calculated from a certified NO <sub>x</sub> monitor at the control device inlet, when the outlet NO <sub>x</sub> monitor is unavailable and proper operation of the emission controls is not verified. These hours are included in missing data lookback and are treated as available hours for percent availability calculations.

(cont.)

**Table 21**  
**MODC Codes and Descriptions for DHV (cont.)**

Code	Parameter(s)	Description
23	NOXR	Maximum Potential NO <sub>x</sub> Emission Rate (MER) for an hour in which flue gases are discharged through an unmonitored bypass stack.
24	NOXR	MCR for an hour in which flue gases are discharged downstream of the NO <sub>x</sub> emission controls through an unmonitored bypass stack, and the add-on NO <sub>x</sub> emission controls are confirmed to be operating properly.
25	NOXR	MER. Use only when a NO <sub>x</sub> concentration full-scale exceedance occurs and the diluent monitor is unavailable.
26	HI	One mmBtu/hr substituted for Heat Input Rate for an operating hour in which the calculated Heat Input Rate is zero or negative.
40	SO2R	Fuel-Specific or Pro-Rated SO <sub>2</sub> Emission Rate default value for use with Formula F-23.
	H2O	Fuel-Specific or Pro-Rated moisture default value.
45	HIT	Maximum Rated Hourly Heat Input Rate (used to determine heat input for LME units generally using long-term fuel flow method).
53	All	Other quality-assured methodologies approved through petition. These hours are included in the missing data lookback and are treated as available hours for percent monitor availability calculations.
54	All	Other quality-assured methodologies approved through petition by EPA. These hours are included in missing data lookback and are treated as unavailable hours for percent availability calculations.
55	All	Other substitute data approved through petition by EPA. These hours are <u>not</u> included in missing data lookback and are treated as unavailable hours for percent availability calculations.

\* EPA has reserved MODCs "01" through "55." MODCs "56" through "99" may be used by vendors and companies for other purposes; do not report these codes in a quarterly report. MODCs "30" and "31" were defined in EDR v2.0 for Ozone Trading Commission (OTC) NBP units only and are no longer allowed.

### Monitoring System ID

*Element Name: MonitoringSystemID*

Report the Monitoring System ID for the appropriate monitoring system that is providing quality-assured data for the hour. For missing data hours and hours in which the flue gases are discharged through an unmonitored bypass stack, leave this field blank. Also, leave this field blank for the calculated SO<sub>2</sub>, NO<sub>x</sub>, and CO<sub>2</sub> hourly mass emission rates. If either: (1) a default high range NO<sub>x</sub> concentration value of 200 percent of the MPC is reported due to a full-scale exceedance of the low range; or (2) a value of 200 percent of the range is reported during a full-scale exceedance of the high range, report the ID number of the NO<sub>x</sub>-diluent monitoring system which is in use at the time of the full-scale exceedance.

For heat input records, report the Monitoring System ID for the O<sub>2</sub> or CO<sub>2</sub> system that provided the value used in the calculation. However, if missing data substitution was used in the MHV record, leave the System ID blank in this DHV record also. Table 22 below summarizes these requirements.

**Table 22**  
**System ID Reporting for Derived Hourly Values**

Parameter Code	Description	System ID to Report
CO2	CO <sub>2</sub> Hourly Mass Rate	Leave blank.
CO2C	CO <sub>2</sub> Concentration (from an O <sub>2</sub> monitor)	CO <sub>2</sub> System ID.
H2O	Moisture (from wet/dry H <sub>2</sub> O system)	H <sub>2</sub> O System ID.
HI	Heat Input	CO <sub>2</sub> or O <sub>2</sub> System ID if CEM. Otherwise, leave blank.
NOX	NO <sub>x</sub> Hourly Mass Rate from NO <sub>x</sub> Concentration and Stack Flow	Leave blank.
	NO <sub>x</sub> Hourly Mass Rate from NO <sub>x</sub> Emissions Rate and Heat Input	Leave blank.
NOXR	NO <sub>x</sub> Emissions Rate	NO <sub>x</sub> System ID for CEM system or NOXE System ID for Appendix E mixed-fuel curve. Otherwise, leave blank.
SO2	SO <sub>2</sub> Hourly Mass Rate	Leave blank.

### Formula Identifier

*Element Name: FormulaIdentifier*

Report the Formula ID from the MONITOR FORMULA DATA record that is used for the calculation of the parameter. Leave this field blank for missing data hours and LME records. If using the Appendix D methodology to determine SO<sub>2</sub>, CO<sub>2</sub>, or Heat Input and burning multiple fuels for the hour, report the Formula ID from the MONITOR FORMULA DATA record with Formula Code D-12, G-4A, or D-15A respectively. If burning a single fuel for the hour, leave this field blank. If using multiple Appendix E curves to determine the NO<sub>x</sub> emission rate for the hour, report the Formula ID from the MONITOR FORMULA DATA record with Formula Code E-2. If using a single curve for the hour, leave this field blank.

**Percent Available***Element Name: PercentAvailable*

For NOXR from a CEM system, H2O, or CO2C, report the percent monitor data availability (PMA) to one decimal place for all hours. Do not report PMA for Heat Input Rate or SO<sub>2</sub>, NO<sub>x</sub>, or CO<sub>2</sub> hourly mass emission rates.

**Operating Condition Code***Element Name: OperatingConditionCode*

This field applies only to Appendix E NOXR data and LME NOXM data. For an Appendix E NO<sub>x</sub> emission rate record (for a unit using one correlation curve for a consistent fuel mixture), report the appropriate code from Table 23 below to indicate the condition that was used to determine the NO<sub>x</sub> emission rate for the hour.

See the instructions for this field in the HOURLY PARAMETER FUEL FLOW DATA record for details about when to report each operating condition code.

**Table 23  
Operating Condition Codes and Descriptions**

<b>Code</b>	<b>Description</b>
B	Unit operated at base load or set point temperature (LME)
C	Controls Operating Properly (LME)
E	Emergency Fuel (Appendix E)
M	Correlation Curve for the Fuel Mixture has Expired (Appendix E)
N	Operating Parameter is Outside of Normal Limits (Appendix E)
P	Unit operated at peak load or higher internal operating temperature (LME)
U	Uncontrolled Hour (Appendix E or LME)
W	Operation Above Highest Tested Heat Input Rate Point on the Curve (Appendix E)
X	Operating Parameter Data Missing or Invalid (Appendix E)
Y	Designated Operational and Control Equipment Parameters within Normal Limits (Appendix E)
Z	Operation Below Lowest Tested Heat Input Rate Point on the Curve (Appendix E)

In the NO<sub>x</sub> record for an LME unit that uses a fuel- and unit-specific default NO<sub>x</sub> emission rate and has NO<sub>x</sub> controls, indicate the status of the NO<sub>x</sub> controls for the hour by reporting:

- C = Controls Operating Properly
- U = Unit Controls Not Operating or Not Operating Properly

In the NO<sub>x</sub> record for an LME combustion turbine that operates principally at base load (or at a set point temperature) but is capable of operating at a higher peak load (or higher internal operating temperature), indicate for each operating hour whether operation was a base load (B) or peak load (P).

- B = Unit operated at base load or set point temperature
- P = Unit operated at peak load or higher internal operating temperature

For all other records, leave this field blank.

### Segment Number

*Element Name: SegmentNumber*

For an Appendix E NO<sub>x</sub> Emission Rate record (for a unit using one correlation curve for a consistent fuel mixture), report the Segment Number (1 – 4) indicating which portion of the correlation curve was used to determine the value for the hour. For operating condition codes N or X, report the segment number that contains the highest NO<sub>x</sub> emission rate on the curve for the fuel. Leave this field blank if the correlation curve was not used for the hour (i.e., the Operating Condition Code is E, M, U, or W).

### Fuel Code

*Element Name: FuelCode*

For LME units, report the type of fuel combusted in the hour. If multiple fuels are burned, report the fuel type used to determine the mass emissions for the parameter in this record (i.e., the fuel with the highest emission factor for the parameter). If records are missing as to which fuel was burned in the hour, report the fuel with the highest emission factor for this parameter of all of the fuels capable of being burned in the unit.

**Table 24**  
**Fuel Codes and Descriptions**

Code	Description
BFG	Blast Furnace Gas
BUT	Butane (if measured as a gas)
CDG	Coal-Derived Gas
COG	Coke Oven Gas
DGG	Digester Gas

(cont.)

**Table 24**  
**Fuel Codes and Descriptions (cont.)**

<b>Code</b>	<b>Description</b>
DSL	Diesel Oil
LFG	Landfill Gas
LPG	Liquefied Petroleum Gas
NNG	Natural Gas (as defined in §72.2)
OGS	Other Gas
OIL	Residual Oil
OOL	Other Oil
PDG	Producer Gas
PNG	Pipeline Natural Gas (as defined in §72.2)
PRG	Process Gas
PRP	Propane (if measured as a gas)
RFG	Refinery Gas
SRG	Unrefined Sour Gas

## 2.4.3 HOURLY FUEL FLOW DATA

### HOURLY FUEL FLOW DATA XML Model

**Figure 11**  
**HOURLY FUEL FLOW DATA XML Elements**

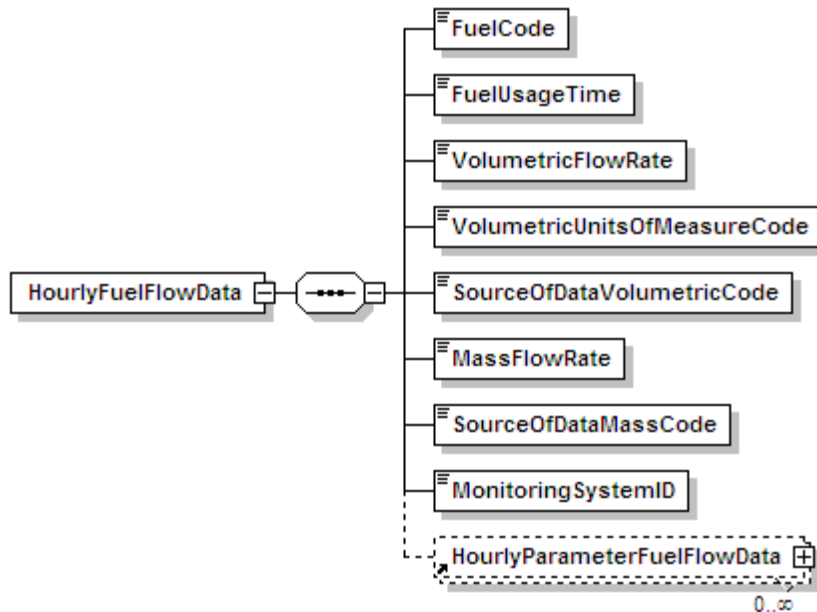

### HOURLY FUEL FLOW DATA Overview

#### Description of Data

Whenever a flowmeter is used to determine heat input rate or SO<sub>2</sub> or CO<sub>2</sub> emissions in accordance with Appendix D, report an HOURLY FUEL FLOW DATA (HFF) record for each type of oil and/or gaseous fuel combusted during each operating hour using the Monitoring System ID associated with the appropriate flowmeter monitoring system. Do not report an HFF record for low mass emissions units (LME) that use a certified Appendix D fuel flowmeter for long term fuel flow purposes; use the LONG TERM FUEL FLOW (LTFF) record.

To report hourly SO<sub>2</sub> mass emission rate, CO<sub>2</sub> mass emission rate and/or Heat Input, you must also submit the appropriate HOURLY PARAMETER FUEL FLOW DATA records associated with each HFF record.

If you measure fuel flow at a common pipe location, report a HFF record using the Stack Pipe ID for each hour in which fuel is combusted by a unit served by the common pipe. Do not report HFF records for the individual units on an hourly basis. Apportion the heat input rate calculated at the common pipe location to each unit, using appropriate time-weighted apportionment formulas based on load (see Appendix F and the MONITOR FORMULA DATA instructions). Report the apportioned hourly heat input rate values in separate DERIVED HOURLY VALUE DATA (DHV)

records for the individual units. Use the hourly heat input rates and operating times from the DHV records to calculate the cumulative heat input values for each unit and report these values in unit-level SUMMARY VALUE DATA records. If you use uncertified fuel flowmeters at the unit and Equation F-21D to apportion the common pipe heat input to the individual units, report HFF only for the common pipe -- do not report any HFF records showing the fuel flow to the individual units.

#### For Oil Fuel Flow Records

Report an HFF for any hour in which oil is combusted as a startup fuel and fuel flow is estimated through tank measurements.

The oil flow rate is the net fuel flow rate to the unit(s). For example, it may represent the difference between the values measured for the main supply and re-circulating oil lines or it may represent the sum of oil flow for two fuel flowmeters measuring the same type of oil to the unit.

For oil fuel flow systems, if the fuel flow system measures mass flow rate of oil directly, leave blank the following data elements:

- Volumetric Flow Rate
- Volumetric Units of Measure Code
- Source of Data Volumetric Code

### **HOURLY FUEL FLOW DATA XML Elements**

#### **Fuel Code**

*Element Name:* FuelCode

Report the type of oil or gaseous fuel combusted during the hour for the system. For oil fuels use the general fuel type codes provided in Table 25 below. For gaseous fuels, you may either report the type of fuel using the General Fuel Type codes (which are consistent with the codes used in the UNIT FUEL DATA record in the monitoring plan) or report more specific fuel codes for the type of gas combusted using one of the Specific Fuel Type codes. Both sets of fuel type codes are listed in Table 26 below. The Fuel Code should match the Fuel Code in the Monitor System record associated with the Monitoring System ID.

#### For Oil Fuel Flow Records

**Table 25**  
**Oil Fuel Flow Fuel Codes and Descriptions**

Code	Description
DSL	Diesel Oil
OIL	Residual Oil
OOL	Other Oil

For Gas Fuel Flow Records

**Table 26**  
**Gas Fuel Flow Fuel Codes and Descriptions**

Code	Description
<b>General Fuel Type Codes</b>	
LPG	Liquefied Petroleum Gas (if measured as a gas)
NNG	Natural Gas
OGS	Other Gas
PNG	Pipeline Natural Gas (as defined in §72.2)
PRG	Process Gas
<b>Specific Fuel Type Codes</b>	
BFG	Blast Furnace Gas
BUT	Butane (if measured as a gas)
CDG	Coal-Derived Gas
COG	Coke Oven Gas
DGG	Digester Gas
LFG	Landfill Gas
PDG	Producer Gas
PRP	Propane (if measured as a gas)
RFG	Refinery Gas
SRG	Unrefined Sour Gas

**Fuel Usage Time**

*Element Name: FuelUsageTime*

Report the fraction of the clock hour during which the unit combusted the specified fuel. You may use any equal increments from hundredths (0.01 hr) to quarters (0.25 hr) of an hour. Do not leave this field blank.

For common pipes, report the cumulative portion of the hour during which the specified fuel was combusted in any of the units served by the common pipe, not to exceed a fuel usage time of 1.00. For example, if a common pipe serves Units 1 and 2 and both units operate for the first 24 minutes (0.40 hr) of the hour and then are both shut down, the fuel usage time is 0.40. If Unit 1 operates only for the first 24 minutes of the hour and Unit 2 operates only for the last 24 minutes of the hour, the fuel usage time is 0.40 hr plus 0.40 hr, or 0.80. If Unit 1 operates for the first 40 minutes of the hour and Unit 2 operates for the last 40 minutes of the hour, report a fuel usage time of 1.00, since for all minutes in the hour, at least one of the units operated.

**Volumetric Flow Rate**

*Element Name: VolumetricFlowRate*

**For Oil Fuel Flow Records**

If the fuel flow system measures the volumetric flow rate of oil, report the net volumetric flow rate, as measured, rounded to one decimal place. This value represents an hourly rate for periods in which the fuel is combusted, not a total flow for the hour. If the hourly oil flow rate is so small that it results in a heat input rate of 0.0 mmBtu/hr (rounded to the nearest tenth) when Equation D-8 is used, you may report, as a default value, the minimum oil flow rate that will give a heat input rate greater than zero. This minimum oil flow rate must be defined in the MONITOR DEFAULT DATA record in the monitoring plan.

For units using Appendix D to account for SO<sub>2</sub> mass emissions you must report mass flow rate. If you use a volumetric flowmeter, report the volumetric flow rate in this field, the mass oil flow rate in the Mass Flow Rate field, and the density value used for the conversion in an HOURLY PARAMETER FUEL FLOW record. If the fuel flow system measures mass flow rate of oil directly, leave this field blank.

**For Gas Fuel Flow Records**

For Appendix D gas systems, the flow rate of gas is measured hourly by the fuel flowmeter system. The flow rate is the net fuel flow rate to the unit(s). For example, it may represent the sum of the gas flow rates for two fuel flowmeters measuring gas to the unit. All values must be reported in 100 standard cubic feet per hour (100 scfh) rounded to one decimal place. This value represents an hourly rate for periods in which the fuel is combusted, not a total flow for the hour. If the hourly gas flow rate is so small that it results in a heat input rate of 0.0 mmBtu/hr (rounded to the nearest tenth) when Equation D-6 is used, you may report, as a default value, the minimum gas flow rate that will give a heat input rate greater than zero. This minimum gas flow rate must be defined in the MONITOR DEFAULT DATA record in the monitoring plan.

**Volumetric Units of Measure Code**

*Element Name: VolumetricUnitsOfMeasureCode*

Report the units of measure used to report volumetric flow rate using the appropriate code from Table 27.

**Table 27**  
**Volumetric Units of Measure Codes and Descriptions**

Fuel Type	Units of Measure Code	Description
Oil	BBLHR	Barrels/Hour
	GALHR	Gallons/Hour
	M3HR	Cubic Meters/Hour
	SCFH	Standard Cubic Feet/Hour
Gas	HSCF	100 Standard Cubic Feet/Hour

Leave this field blank only for Oil HFF records, where the fuel flow system measures mass flow rate of oil directly.

**Source of Data Volumetric Code**

*Element Name:* *SourceOfDataVolumetricCode*

Report the Source of Data Volumetric Code that indicates the type of value reported for gas flow or volumetric oil flow rate, as shown in Table 28.

**Table 28**  
**Source of Data Volumetric Codes and Descriptions**

Code	Fuel Type	Description
0	Oil or Gas	Measured Data
1	Oil or Gas	Substitute Data Using Lookback Procedures
3	Oil or Gas	Maximum Potential Fuel Flow Rate (simplified missing data procedure for peaking units, only)
4	Oil or Gas	Emergency Fuel (maximum unit fuel flow rate)
5	Oil	Igniter Oil from Tank Measurements
6	Oil	Uncertified OFFM to Measure Igniter Oil
9	Oil or Gas	Default Minimum Fuel Flow Rate

Leave this field blank only for Oil HFF records, where the fuel flow system measures mass flow rate of oil directly.

Do not leave this field blank for gas fuel flow records.

**Mass Flow Rate***Element Name: MassFlowRate*For Oil Fuel Flow Records

Report the Mass Flow Rate of oil either measured directly by a fuel flowmeter system or calculated from the volumetric flow rate measured by a fuel flowmeter system. All values must be reported in lb/hr, rounded to one decimal place. This value represents an hourly rate for the period in which fuel is combusted, not total flow for the hour.

For units using Appendix D to account for SO<sub>2</sub> mass emissions, you must report mass flow rate in order to calculate SO<sub>2</sub> mass emissions. Where the density of the oil is determined by the applicable ASTM procedures referenced in Part 75, use Equation D-3 to calculate the mass flow rate of oil (in lb/hr).

$$OIL_{rate} = V_{oil-rate} \times D_{oil} \quad \text{(Equation D-3)}$$

Where:

OIL <sub>rate</sub>	=	Mass rate of oil consumed per hr (lb/hr)
V <sub>oil-rate</sub>	=	Volume rate of oil consumed per hr, measured in scfh, gal/hr, barrels/hr, or m <sup>3</sup> /hr (rounded to one decimal place)
D <sub>oil</sub>	=	Density of oil, measured in lb/scf, lb/gal, lb/barrel, or lb/m <sup>3</sup>

However, for Subpart H units using Appendix D only for heat input determination, you may measure and report either mass flow rate or volumetric flow rate of oil. If you use volumetric flow rate and gross calorific value (GCV) to determine hourly heat input rate, leave this field blank.

For Gas Fuel Flow Records

Leave this field blank.

**Source of Data Mass Code***Element Name: SourceOfDataMassCode*For Oil Fuel Flow Records

Report one of the following codes to indicate the type of value reported for mass oil flow rate. If the mass oil flow value was calculated from a volumetric oil flow value, report code 2, regardless of what Source of Data code was reported for the volumetric oil flow. For emergency fuels where certified fuel flowmeters are used instead of the maximum unit fuel flow rate for heat input, use either code 0, 1, 2, or 3 as appropriate. Do not use code 4 unless the maximum unit fuel flow rate option is used for reporting heat input for the emergency fuel.

**Table 29**  
**Source of Data Mass Codes and Descriptions**

Code	Description
0	*Measured Data (using a mass flowmeter)
1	Substitute Data Using Lookback Procedures
2	*Mass Flowrate Derived From Volumetric Value.
3	Maximum Potential Fuel Flow Rate (simplified missing data procedure for peaking units, only)
4	Emergency Fuel (maximum unit fuel flow rate)
5	Igniter Oil From Tank Measurements
6	Uncertified OFFM to Measure Igniter Oil
9	Default Minimum Fuel Flow Rate

\* Including measured or derived mass data, for an emergency fuel where a certified mass or volumetric oil flowmeter is used.

Do not leave this field blank if fuel flow is reported in the Mass Flow Rate element.

### **Monitoring System ID**

*Element Name: MonitoringSystemID*

Report the three character Monitoring System ID for the gas or oil fuel flowmeter system.

For hours in which you report the source of the fuel flow rate data (Source of Data Volumetric Code or Source of Data Mass Code element) as codes 4, 5, or 6 for "Emergency Fuels," where the maximum unit fuel flow rate is used, or as "Igniter Oil from Tank Measurements," or "Uncertified OFFM to Measure Igniter Oil," leave the Monitoring System ID blank.

*[This page intentionally left blank.]*

## 2.4.3.1 HOURLY PARAMETER FUEL FLOW DATA

### HOURLY PARAMETER FUEL FLOW DATA XML Model

**Figure 12**  
**HOURLY PARAMETER FUEL FLOW DATA XML Elements**

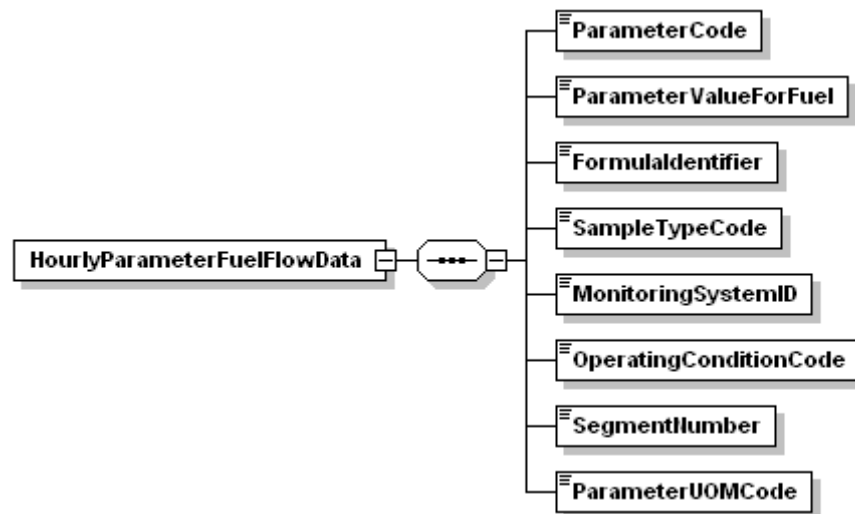

### HOURLY PARAMETER FUEL FLOW DATA Overview

#### Description of Data

For each HOURLY FUEL FLOW DATA (HFF) record, submit HOURLY PARAMETER FUEL FLOW DATA records to provide the following information, as applicable:

- Gross calorific value (GCV) of the fuel;
- Density of the oil, if oil is measured on a volumetric basis and is required to be converted to a mass basis (for locations that report SO<sub>2</sub>);
- Sulfur content or default SO<sub>2</sub> emission rate for the fuel, for locations that report SO<sub>2</sub>;
- Hourly heat input rate and/or SO<sub>2</sub>, and CO<sub>2</sub> mass emission rate values, as calculated from the hourly fuel flow; and
- NO<sub>x</sub> emission rate determined using an Appendix E correlation curve for the single fuel.

Submit an HOURLY PARAMETER FUEL FLOW DATA record separately for each parameter as applicable. For units using Appendix D to account for heat input rate and SO<sub>2</sub> and CO<sub>2</sub> emissions, for each hour in which any type of oil or gas is burned, report an HOURLY PARAMETER FUEL FLOW DATA record and the corresponding HFF record(s) for each fuel combusted during the hour.

## HOURLY PARAMETER FUEL FLOW DATA XML Elements

### Parameter Code

*Element Name: ParameterCode*

Report the parameter for the HOURLY PARAMETER FUEL FLOW DATA record using one of the codes in Table 30:

**Table 30**  
**Parameter Codes and Descriptions for HOURLY PARAMETER FUEL FLOW**

Code	Description
CO2	CO <sub>2</sub> Mass Emission Rate (tons/hr)
DENSOIL	Density of Oil
FC	Carbon-Based F-Factor (for CO <sub>2</sub> calculation)
GCV	Gross Calorific Value for Oil or Gas
HI	Heat Input Rate (mmBtu/hr)
NOXR	NO <sub>x</sub> Emission Rate (lb/mmBtu) (Appendix E )
SO2	SO <sub>2</sub> Hourly Mass Rate (lb/hr)
SO2R	Default SO <sub>2</sub> Emission Rate (lb/mmBtu)
SULFUR	Sulfur Content (percent by weight)

### Parameter Value for Fuel

*Element Name: ParameterValueForFuel*

If the Parameter Code is "SO2," report the SO<sub>2</sub> mass emission rate for the fuel in lb/hr calculated using Equation D-2, D-4, or D-5 from Appendix D to Part 75.

If the Parameter Code is "CO2," report the CO<sub>2</sub> mass emission rate for the fuel in tons/hr calculated using Equation G-4 from Appendix G to Part 75.

If the Parameter Code is "HI," report the Heat Input rate for the fuel calculated by multiplying the heat content (GCV) of the fuel by the hourly fuel flow rate. Report this value in units of mmBtu/hr.

If the Parameter Code is "NOXR," report the NO<sub>x</sub> emission rate for the fuel in lb/mmBtu determined using an Appendix E correlation curve.

If the Parameter Code is "GCV," report the gross calorific value used to calculate heat input. Be sure to use the units of measure that correspond to the units used to report the fuel flow.

If the Parameter Code is "DENSOIL," report the density of oil used to calculate mass oil flow rate from volumetric oil flow rate. Be sure to use the units of measure that correspond to the units used to report the fuel flow.

If the Parameter Code is "FC" report the carbon based F-factor for this fuel, as used to calculate CO<sub>2</sub> using equation G-4.

If the Parameter Code is "SULFUR," for oil fuel flow records, if percent sulfur is measured, the actual value may be reported to the appropriate number of decimal places in Table 30. Use Table D-4 in Appendix D to Part 75 to determine what value you should report in this field. For gas fuel flow records report the sulfur content of the gaseous sample in grains/100 scf. Use Table D-5 in Appendix D to Part 75 to determine the correct value. If the sulfur content for any sample(s) is 0.04 grains/100 scf or less, report 0.1 grains/100 scf.

If the Parameter Code is "SO2R," report the default SO<sub>2</sub> emission rate for natural gas of 0.0006 lb/mmBtu for pipeline natural gas if pipeline natural gas is combusted. If calculating a default emission rate using Equation D-1H, report the default rate in this field.

For all parameter codes, report the value to the appropriate number of decimal places in Table 31.

**Table 31**  
**Precision of Reported Values for Parameter Value for Fuel**

Parameter Codes		Number of Decimal Places
CO2, FC, GCV, HI		One
DENSOIL		Five
NOXR		Three
SO2	Oil	One
SO2	Gas	Five
SO2R		Five
SULFUR	Oil	Four
SULFUR	Gas	One

### Formula Identifier

*Element Name: FormulaIdentifier*

Report the code corresponding to the formula listed in the monitoring plan used to calculate the parameter for the HOURLY PARAMETER FUEL FLOW DATA record. For parameters GCV, FC, DENSOIL, and SULFUR, leave this field blank. For parameter SO2R, report this field if using a D-1H formula, otherwise leave it blank.

**Sample Type Code***Element Name: SampleTypeCode*

Report the type of sample used to determine the GCV, density, or sulfur content using one of the codes in Table 32.

**Table 32**  
**Sample Type Codes and Descriptions**

Code	Fuel	Parameters	Description
0	Gas	GCV, SULFUR	Actual Measured Hourly Average Sample from GCH
1	Oil	GCV, DENSOIL, SULFUR	Actual Measured Value from Oil Composite or Tank Sample
2	Gas	GCV, SULFUR	Actual Measured Value from a Daily Sample
	Oil	GCV, DENSOIL, SULFUR	
3	Gas	GCV	Actual Measured GCV from Most Recent Monthly Sampling
4	Gas	GCV, SULFUR	Actual Measured Value from Most Recent Shipment or Lot
5	Gas	SULFUR	Highest Daily Sample in 30 Daily Samples
	Oil	GCV, DENSOIL, SULFUR	
6	Gas	GCV, SULFUR	Highest Sampled Value in Previous Calendar Year (or a higher sampled value, superseding the assumed value)
	Oil	GCV, DENSOIL, SULFUR	
7	Gas	GCV, SULFUR	Maximum Value Allowed by Contract (or a higher sampled value, superseding the assumed value)
	Oil	GCV, DENSOIL, SULFUR	
8	Gas	GCV, SULFUR	Missing Data (Maximum Potential Value for missing data or emergency fuel from Table D-6 Appendix D section 2.4.1)
	Oil	GCV, DENSOIL, SULFUR	

**Monitoring System ID***Element Name: MonitoringSystemID*

For Appendix E NO<sub>x</sub> rate records (Parameter NOXR), report the three-character Monitoring System ID for the applicable NOXE system. If there is no applicable NOXE system (e.g., for emergency fuel records) leave this field blank. Also leave this field blank for other parameters.

**Operating Condition Code***Element Name: OperatingConditionCode*

For Appendix E NO<sub>x</sub> rate records (Parameter NOXR), report the appropriate code from Table 33 that indicates the condition that was used to determine the NO<sub>x</sub> emission rate for the hour.

**Table 33  
Operating Condition Codes and Descriptions**

Code	Description
E	Emergency Fuel
M	Correlation Curve for the Fuel Mixture Has Expired
N	Operating Parameter Is Outside of Normal Limits
U	Uncontrolled Hour
W	Operation Above Highest Tested Heat Input Rate Point on the Curve
X	Operating Parameter Data Missing or Invalid
Y	Designated Operational and Control Equipment Parameters within Normal Limits
Z	Operation Below Lowest Tested Heat Input Rate Point on the Curve

When to Report "E"

Report "E" if the unit burned an emergency fuel during the hour and you do not have a separate correlation curve for the emergency fuel. For these hours, report the fuel-specific maximum potential NO<sub>x</sub> emission rate (MER) in the *ParameterValueForFuel* field.

When to Report "M"

When 20 calendar quarters have elapsed since the quarter of the last Appendix E test for a particular type of fuel, without a subsequent re-test being done, the correlation curve for that fuel type has expired. From that point on (i.e., starting with the first hour after the end of the 20th quarter), the previous correlation curve is considered invalid, and you must report the fuel-specific MER for every hour in which the fuel is combusted, until a successful re-test has been completed. Report "M" for each such hour.

When to Report "N"

Report "N" if a unit operating parameter is outside of normal limits. For example, report "N" when excess O<sub>2</sub> exceeds by more than 2.0 percent the excess O<sub>2</sub> value recorded at the same operating heat input rate during the last NO<sub>x</sub> emission rate test.

Also, if one or more parameters are outside the normal limits for > 16 consecutive operating hours, a re-test is required within 30 unit operating days or 180 calendar days (whichever occurs first -- see Appendix E, Section 2.3). Beginning with the 17th consecutive "out-of-spec" operating hour and continuing until the re-test is completed, continue to report "N" for each hour of combustion of the fuel(s) that triggered the need for the re-test.

Use missing data procedures from Appendix E for any hour in which "N" is indicated. These procedures require you to substitute the highest tested NO<sub>x</sub> emission rate on the curve for the fuel.

Note: If fuel flow rate and gross calorific value data are missing, use the missing data procedures in Appendix D, not Appendix E.

#### When to Report "U"

For units with add-on NO<sub>x</sub> controls only. Report "U" if any parameter used to verify proper operation of the emission controls is outside of normal limits (or the control equipment is not functioning). For these hours, report the fuel-specific NO<sub>x</sub> MER in the Parameter Value for Fuel field.

#### When to Report "W"

Report "W" if the hourly heat input rate is higher than the maximum heat input rate correlated on the curve. Use the missing data procedures in section 2.5.2.1 of Appendix E when this occurs. During your next periodic or quality assurance/quality control related testing, test under conditions more representative of your maximum potential heat rate. If possible, use the new maximum heat input rate as the highest heat input point during the next test.

#### When to Report "X"

For missing or invalid excess O<sub>2</sub> or other operating parameter data, report "X" and report the highest NO<sub>x</sub> emission rate on the curve for the fuel. This indicates that the hour is not demonstrated to be within the specified limits in Section 2.3 of Appendix E, but it also is not demonstrated to be outside the specified limits. (Note that the use of the "X" value is optional, you may choose instead to treat these hours as out-of-spec.) Hours marked with "N" count towards the 16 consecutive unit operating hours before retesting is required, while hours marked with "X" do not count for this purpose. In either case, the data count against the availability of data where the unit operates within the parameters. If the data availability falls below 90.0 percent, the Agency may require retesting.

#### When to Report "Z"

Report "Z" if the hourly heat input rate is below the lowest heat input rate. In this case it is not necessary to verify that the operational parameters are within any specified limits. Report the same NO<sub>x</sub> emission rate recorded during testing at the lowest heat input rate.

**Segment Number***Element Name: SegmentNumber*

For an Appendix E NO<sub>x</sub> Emission Rate record (for a unit using one correlation curve for a consistent fuel mixture), report the Segment Number (1 – 4) indicating which portion of the correlation curve was used to determine the value for the hour. For operating condition codes N or X, report the segment number that contains the highest NO<sub>x</sub> emission rate on the curve for the fuel. Leave this field blank if the correlation curve was not used for the hour (i.e., the Operating Condition Code is E, M, U, or W).

**Parameter UOM Code***Element Name: ParameterUOMCode*

Report the code from Table 34 that identifies the unit of measure in which the Parameter Value for Fuel is reported. Be sure it corresponds properly to the units of measure in which the Hourly Fuel Flow rate was reported.

**Table 34**  
**Units of Measure Codes and Descriptions for HOURLY PARAMETER FUEL FLOW**

Parameter	Code	Description
CO2	TNHR	Tons per Hour
DENSOIL	LBBBL	Pounds per Barrel
	LBGAL	Pounds per Gallon
	LBM3	Pounds per Cubic Meter
	LBSCF	Pounds per Standard Cubic Foot
FC	SCFCBTU	CO <sub>2</sub> Standard Cubic Feet/mmBtu
GCV	BTUBBL	BTU per Barrel
	BTUGAL	BTU per Gallon
	BTULB	BTU per Pound
	BTUM3	BTU per Cubic Meter
	BTUSCF	BTU per Standard Cubic Foot
	BTUHSCF	BTU per 100 Standard Cubic Feet
HI	MMBTUHR	Million BTU per Hour
SO2	LBHR	Pounds per Hour
SO2R, NOXR	LBMMBTU	Pounds per Million BTU
SULFUR	PCT	Percent by Weight
	GRHSCF	Grains per 100 Standard Cubic Feet

*[This page intentionally left blank.]*

## 2.5 LONG TERM FUEL FLOW DATA

### LONG TERM FUEL FLOW DATA XML Model

**Figure 13**  
LONG TERM FUEL FLOW DATA XML Elements

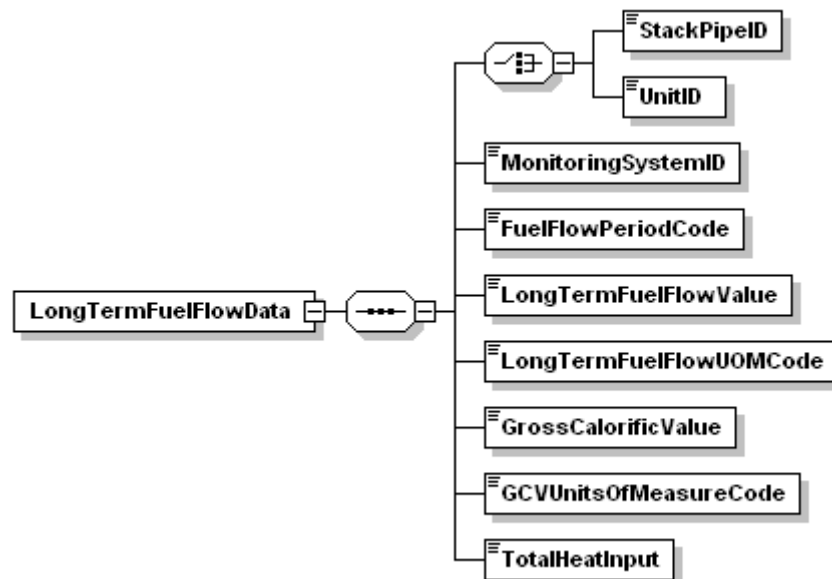

### LONG TERM FUEL FLOW DATA Overview

#### Description of Data

If you have a qualifying low mass emissions (LME) unit or group of units and use a long term fuel flow system to measure oil or gas to calculate heat input, report a LONG TERM FUEL FLOW DATA record for each long term oil (LTOL) monitoring system and each long term gas (LTGS) monitoring system used during the quarter or reporting period.

For a group of LME units served by a common pipe (or supply tank), you must define a LTOL or LTGS monitoring system in the monitoring plan for the pipe or tank. In both cases (i.e., for common pipe or tank), the pipe or tank ID number must begin with a "CP" prefix (e.g., CP001). If two or more common pipes or tanks of *different* fuel types supply the same group of LME units, you must define a separate LTOL or LTGS system for each pipe or tank. If two or more pipes or tanks supply the same type of fuel to a group of LME units, you may represent it as a single LTOL or LTGS system.

## LONG TERM FUEL FLOW DATA XML Elements

### Unit ID or Stack Pipe ID

*Element Name:* *UnitID* or *StackPipeID*

Report either the Unit ID or Stack Pipe ID for the long term fuel flow location. This is the alphanumeric code assigned by a source to identify a unit, stack, or pipe.

### Monitoring System ID

*Element Name:* *Monitoring System ID*

Report the monitoring system ID, either LTOL or LTGS, for the long term fuel flow (LTFF) system.

### Fuel Flow Period Code

*Element Name:* *FuelFlowPeriodCode*

If this location is subject to an ozone season program and this is a second quarter emissions file, report either "A" to indicate that this record contains long term fuel flow for the month of April, or "MJ" to indicate that this record contains long term fuel flow for May and June. Otherwise, leave this field blank.

### LTFF Value

*Element Name:* *LongTermFuelFlowValue*

Report the total fuel flow recorded for the quarter, reporting period, or fuel flow period to zero decimal places. If you measure in units other than gallons, pounds or standard cubic feet, convert the reading to allowable units by using conversion equations.

### Instructions for Using Billing Records

- If you have daily billing records, then use the daily fuel usage to apportion the fuel flow on a daily basis to hours within the ozone season or quarter beginning on the first operating day of the ozone season or quarter and ending on the last operating day of the ozone season or quarter.

Example 1. If a billing period starts on June 15 and ends on July 16 and the bill includes daily usage, use the daily quantities to determine which fuel was combusted during June (attributed to the second quarter) and which fuel was combusted during July (attributed to the third quarter).

- If the bill does not specify daily fuel usage, apportion fuel based on unit output, as reported in the OPERATING HOUR DATA record.

Example 2. If the billing period starts on June 15 and ends on July 16, and the bill only has total fuel combusted during the period, apportion the fuel into June and July based on the unit output for the billing period. Thus, if 75 percent of the unit output between June

15 and July 16 occurred during June, then apportion 75 percent of the total fuel into June and 25 percent into July.

- It is the responsibility of the owner/operator to obtain all necessary billing records in time to ensure timely quarterly report submissions.

#### Instructions for Using Tank Drop Measurements

- For year-round reporting, measure the tank volume (the beginning and ending LTFF measurement) within no more than 48 hours of the beginning or end of a quarter.

Example 3. If you measure the level of oil in a tank on December 30 or 31 or on January 1 or 2, use this measurement (compared to the baseline value at the beginning of the quarter) to calculate the amount of fuel combusted during the quarter (even if the measurement was taken in January). Use this measurement as the baseline for determining the amount of fuel combusted during the next quarter. When apportioning heat input based on unit output only, use output from the beginning and end of the quarter, not the output corresponding to the beginning and end of the actual measurement period.

- Perform as many measurements as necessary to accurately determine fuel usage during the measurement period. The Agency recommends performing measurements before and after fuel is added to a tank unless you know the exact volume of fuel added to the tank.
- If a unit operated for only a very short period or used only a very limited amount of fuel during a quarter or reporting period so that a tank drop measurement will not yield an accurate estimate of the fuel combusted during the quarter, use the unit's maximum rated heat input for each hour of operation during that quarter. Report a method of determination code (MODC) of "45" in the DERIVED HOURLY VALUE DATA (DHV) record for Total Heat Input (HIT) for each hour.

#### Instructions for Using Certified Fuel Flowmeters

- When a certified Appendix D fuel flowmeter is used for long term fuel flow purposes, you are required to record hourly fuel flow rates. You must also submit MONITORING SYSTEM FUEL FLOW DATA in the monitoring plan and must submit the results of all periodic fuel flowmeter quality assurance tests. However, reporting of hourly fuel flow rate information is not required. Therefore, do not report HOURLY FUEL FLOW DATA (HFF) records for LME units.
- Use the recorded hourly fuel flow rates, fuel usage times (if available), and the density of the fuel (if needed) to determine the total mass or volume (as applicable) of each type of fuel combusted during the reporting period. Then, use Equation LM-2 or LM-3 in §75.19, as appropriate, to calculate the heat input from each type of fuel combusted during the reporting period. Add together all of the reporting period heat input values for all fuels, according to Equation LM-4. Then, apportion the total heat input for the reporting period to each operating hour in the period, using Equations LM-5 through LM-8A (as applicable) replacing the term "quarter" with the term "reporting period."

- When calculating the total mass or volume of fuel combusted, if hourly fuel usage times are not available, use a value of 1.00 for each operating hour in the reporting period.
- If any fuel flowmeter data are missing for any hour(s) in the reporting period, you must provide substitute data for those hours, using either: (1) the load-based missing data procedures in Appendix D (if these procedures are programmed in the Data Acquisition and Handling System (DAHS)); or (2) the maximum system fuel flow rate in MONITORING SYSTEM FUEL FLOW DATA record).

### Long Term Fuel Flow UOM Code

*Element Name: LongTermFuelFlowUOMCode*

Report the units of measure in which you are reporting fuel flow using one of the following uppercase codes in Table 35.

**Table 35**  
**Long Term Fuel Flow UOM Code**

Code	Description
GAL	Gallons (oil)
LB	Pounds (oil)
SCF	Standard Cubic Feet (gas)

### Gross Calorific Value

*Element Name: GrossCalorificValue*

Report the heat content or gross calorific value (GCV) of the fuel from Table LM-5 of §75.19 or the highest GCV recorded in the previous calendar year from fuel sampling and analysis according to the procedures of Appendix D to Part 75. If you measure in units other than those listed below, convert to an allowable unit by using appropriate conversion equations. Report the value to one decimal place.

### GCV Units of Measure Code

*Element Name: GCVUnitsofMeasureCode*

Report the units of measure for GCV using one of the uppercase codes in Table 36.

**Table 36**  
**GCV Units of Measure Code**

Code	Description
BTUGAL	Btu per Gallon
BTULB	Btu per Pound
BTUSCF	Btu per Standard Cubic Feet

### **Total Heat Input**

*Element Name: TotalHeatInput*

Calculate and report the total heat input (mmBtu) measured by the LTFF system for the quarter or reporting period using the appropriate heat input formula from §75.19 (e.g., LM-2, LM-3). Report the value to zero decimal places.

### *Specific Considerations*

- If this system is the only LTFF system used for the unit or group of units, apportion this heat input to the unit operating hours in the quarter (or reporting period) using the appropriate equation in §75.19. If two or more LTFF systems are used during the quarter or reporting period, sum the total heat input values from all systems before apportioning heat input to the unit operating hours.
- For a single LME unit which is not part of a group of LME units, the total heat input values for all LTFF systems used during the quarter must equal the quarterly unit heat input value reported in the SUMMARY VALUE DATA record.
- For a group of LME units served by one or more common pipes or tanks, you must report both LTFF and SUMMARY VALUE DATA records under each common pipe (or tank) ID number. For each common pipe or tank ID, the total heat input reported in the LTFF record(s) must equal the quarterly heat input reported in the SUMMARY VALUE DATA record.
- For any hour during which the unit is burning a secondary fuel that is not measured by a long term fuel flow system, you must calculate the total heat input for the hour using the maximum rated hourly heat input rate for the unit. Report an MODC of "45" in the DHV record for (HIT) for the hour.
- If a unit (or group of units linked to a common pipe) using LTFF to determine heat input burns fuel, but does not generate any load during the reporting period, apportion the total heat input based on operating time instead of load using the appropriate equation in §75.19.

*[This page intentionally left blank.]*